



Innovation in every connection.

# Single Phase Distribution.

Elucian® Single Phase solutions. An extensive range of consumer units and protection devices, packed with advanced features for safety, flexibility, and reliability.



Elucian® by Click® brings to market a comprehensive Consumer Unit and Circuit Protection range.

[Get to know us](#) 

### Designed with installers in mind

Through close collaboration with contractors and installers, our product range has been tailored to meet industry needs while ensuring full compliance with the latest regulations.

Designed with the installer in mind, Elucian® is an extensive range of metal consumer units that covers a broad range of installations and offers a number of features and benefits that will enhance the products' convenience, flexibility and safety properties.

# The Elucian® consumer units range has been designed to ensure compliance with BS 7671.

Our engineers have considered how installers need to comply with the UK wiring regulations when installing consumer units in properties across the UK. The Elucian® range has comprehensive options for every installation. These consist of Main Switch units, RCBO units, Split Load units and our Combination units.

## Explore Three Phase

Explore our full range of Three Phase Distribution Boards, Circuit Protection Devices and accessories.

Three Phase on [Page 64](#)



## Overload Protection

(536.4.3.2) & (536.4.202)

RCCBs are not designed to be able to withstand overload current. Care should be given when assessing the likely loading of the final circuits.

The designer and installer must therefore select the correct rated device from the options we have made available; 63A, 80A or 100A. To make this process easier we have installed 80A devices as standard.

## Types of RCD

(531.3.3)

Many different types of RCD exist. BS 7671 recognises Types AC, A, F and B. Currently AC RCDs are recognised as acceptable for general purpose. However, if the installation has any DC components or frequency alterations due to connected loads one of the other types must be selected.

As most installations in the UK now have some DC components, Type A RCDs are the basic type of device selected for use.

Where higher frequencies exist, or where larger DC components exist, Type F or Type B RCDs should be selected for use. Furthermore, there are several specific requirements in BS 7671 where either Type F or Type B devices are necessary.

## Over-voltage Protection

(Section 443) & (Section 534)

SPDs offer very effective protection against over-voltage. Section 443 covers the requirements for consideration when selecting SPDs in the electrical system.

Section 534 confirms what SPDs are required and where they must be installed within the electrical system.

We have designed our SPD consumer unit to incorporate a type 2 device. These devices offer protection from man-made over-voltages or lightning strokes within the vicinity of the installation.

Having SPDs installed adjacent to the main switch allows for compliance with the maximum cable length from the SPD to Earth.

## Division of Installation

(Section 314)

This regulation set requires the designer and installer to ensure the installation is divided up as necessary to:

- (i) Avoid danger and minimise inconvenience in the event of a fault.
- (ii) Facilitate safe inspection, testing & maintenance.
- (iii) Take account of hazards that may arise from the failure of a single circuit.
- (iv) Reduce the possibility of unwanted tripping of RCDs due to excessive protective conductor current or due to fault.
- (v) Mitigate the effects of electromagnetic disturbances.
- (vi) Prevent the indirect energization of a circuit intended to be isolated.



# Overload protection of RCCBs...

These devices may be overloaded if the combined outgoing current from the final circuits is greater than the rating of the RCCB. Therefore, we provide an 80A device as standard with the ability to change this to a 100A, or reduce to a 63A if required.

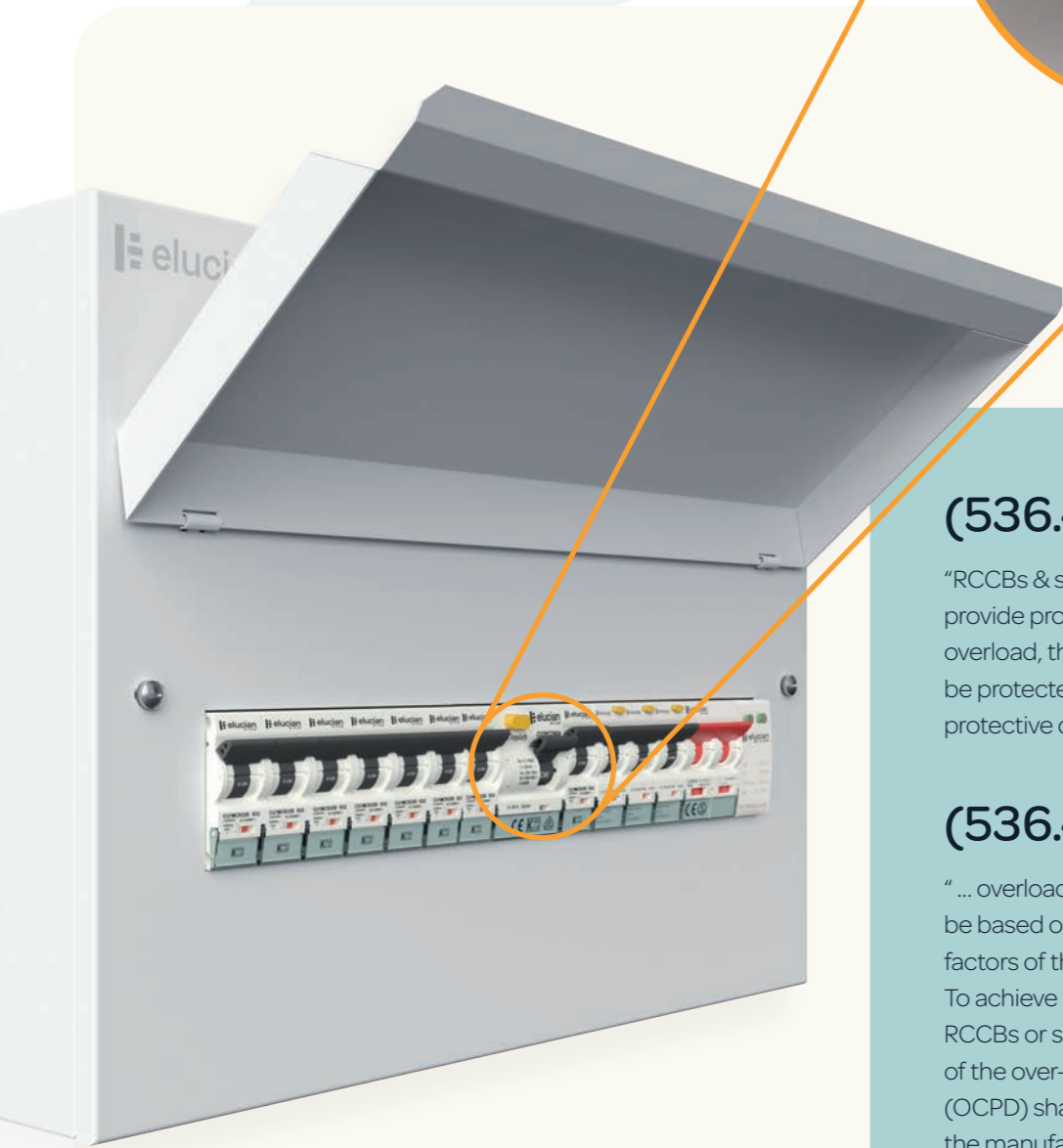

## (536.4.3.2)

“RCCBs & switches do not provide protection against overload, therefore they shall be protected by an overcurrent protective device.”

## (536.4.202)

“... overload protection shall not solely be based on the use of diversity factors of the downstream circuits. To achieve overload protection of RCCBs or switches, the rated current of the over-current protective device (OCPD) shall be selected according to the manufacturers instructions”.

# Comply with the regs...

Regulations 536.4.3.2 and 536.4.202 require the designer to understand the loading profile of the RCCBs within the consumer unit. RCCBs will protect a number of outgoing circuits at the same time.

## Method 1

Ensure the full load of all final circuits being protected are less than the rating of the RCCB. The installer will need to consider diversity for the final circuits but, not use diversity as the sole factor for calculating the total current downstream of the device.

## Method 2

Ensure the main protective device is of a size to limit the total amount of amps upstream of the devices.

### Example 1:

This install would not comply. RCCB1 could be subject to overload.

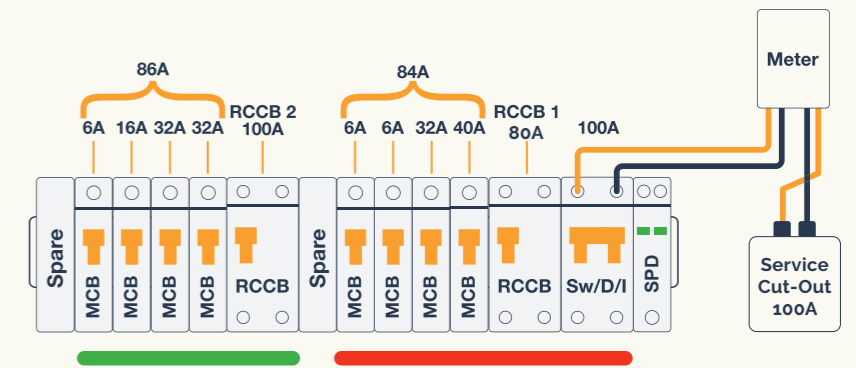

### Example 2:

This installation would comply. Although RCCB1 could potentially become overloaded, the protective device at the origin would offer overload protection.

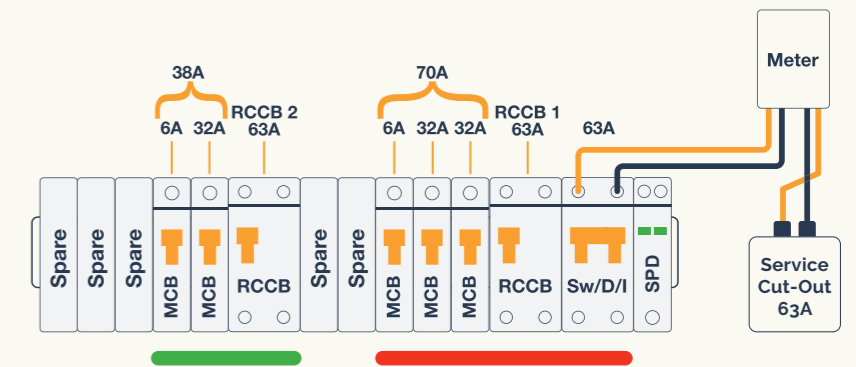

### Example 3:

RCBOs offer comprehensive protection as each device is rated to the circuit.

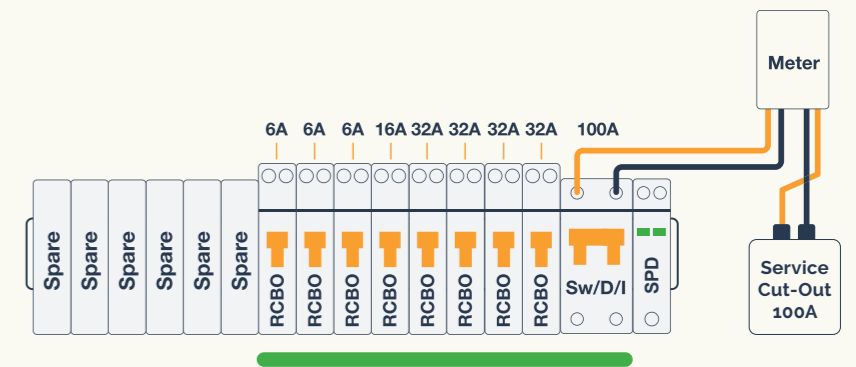

# RCCB & RCBO Protection Devices...

RCCBs are available in a number of common types; AC, A, F or B. Dependant on the characteristics of the final circuit/s being controlled, the type of RCCB selected is very important. If it is believed DC current could be present in the protected circuit/s due to the equipment connected, the designer should select a device capable of working with that DC current present.

General RCCBs are designed to operate instantaneously without intentional delay; because of this they are not designed to discriminate in the event of a fault. Therefore, if two general RCCBs were to be installed in series, both may operate when a fault presents itself. To avoid this, selectivity is essential between the installed devices to reduce the unintentional operation of a device upstream from the leakage to Earth.

Installing the correct type of device is essential if it is believed DC current could be present within the installation. It is important to install an RCD type that is capable of handling DC current ahead of a device that isn't able to operate with these currents.

Such as:

kWh	C/U with Type AC RCCB	Mini C/U with Type A RCCB	●
kWh	C/U with Type A RCCB	Mini C/U with Type A RCCB	●
kWh	C/U with Type A RCCB	Mini C/U with Type B RCCB	●
kWh	C/U with Type B RCCB	Mini C/U with Type A RCCB	●



## Type A RCCB



In today's installations the majority of equipment does have some residual DC current due to the internal electronics. The magnitude of this current can have a detrimental effect on the effectiveness of the protective device.

Type A devices have the ability to continue to work with up to 6mA of DC fault current present. This amount of fault current has been shown to stop AC Type RCCBs/RCBOs from working within the maximum time permitted in BS7671.

RCCB - Residual Current Operated Circuit Breaker, without integrated overcurrent protection.

Full listings **Page 49**



## RCBO Protection

These devices combine the functionality of an MCB and RCCB into one single device/module. Available as a Type A RCD with different inrush curve types B or C, these protection devices have been miniaturised to maximise the available space above for termination or final circuits.

The Neutral fly lead has been made long enough to ensure safe connection to the dedicated Neutral bars.

RCBO - Residual Current Operated Circuit Breaker, with integrated overcurrent protection.

Full listings **Page 46-49**





# Safeguard your installations with Surge Protection.

$I_{imp}$  - Impulse current of 10/350  $\mu$ s waveform.

$I_n$  - Surge current of 8/20  $\mu$ s waveform associated with Type 2 SPDs.

$U_p$  - The residual voltage that is measured across the terminal of the SPD when  $I_n$  is applied.

$U_c$  - The maximum voltage which may be continuously applied to the SPD without it conducting.

$I_{max}$  - Maximum short circuit current of the device.

Full listings **Page 46**



## Transient Over-voltages

Many installations across the UK have electronic components within them. Surge protection will offer those devices and appliances protection from over-voltage.

Products such as computers, printers, flat screen televisions, alarms, microwaves and washing machines are commonplace. These can all be vulnerable to transient over voltages, which can significantly reduce the equipment's lifespan through degradation and damage.

A transient over voltage or surge is a short duration increase in voltage measured between two or more conductors. In short, this means anything from microseconds (millionths of a second) to a few milliseconds (thousandths of a second) in duration.

## Covers Overvoltage Control (443.4.1 & 443.4.2)

Protection against overvoltages shall be provided where the consequence caused by overvoltage could:

- (i) Result in serious injury to, or loss of, human life,
- (ii) Result in significant financial loss or data loss

For all other cases, protection against transient overvoltages shall be provided unless the owner of the installation declares it is not required due to any loss or damage being tolerable and they accept the risk of damage to equipment and any consequential loss.

Protection against overvoltages shall be considered in the case of equipment likely to produce switching overvoltages or disturbances exceeding the values according to the voltage category of the installation, e.g. where an LV generator supplies the installation or where inductive or capacitive loads (e.g. motors, transformers, capacitor banks) storage units or high-current loads are installed.



## SPD Type 2

SPD which can prevent the spread of over-voltages in the electrical installations and protects equipment connected to it. It usually employs metal oxide varistor (MOV) technology and is characterised by an 8/20  $\mu$ s current wave.

SPD listing **Page 46**



Functional, stylish,  
and innovative.

## Consumer Units

Our Elucian® range of consumer units provides an exceptional option for any residential or light commercial environment. Packed with features making installation quick and simple for electricians, with a clear labelling kit for easy identification for the customer. A great range of configurations and sizes makes Elucian® perfect for any installation requirement.

# Features & Benefits



## Metal Consumer Units

All Elucian® consumer units are constructed using non-combustible and robust metal housings. They ensure compliance against the third amendment which was added to the BS 7671 wiring regulations in 2015 requiring consumer units in domestic premises to have a non-combustible enclosure.

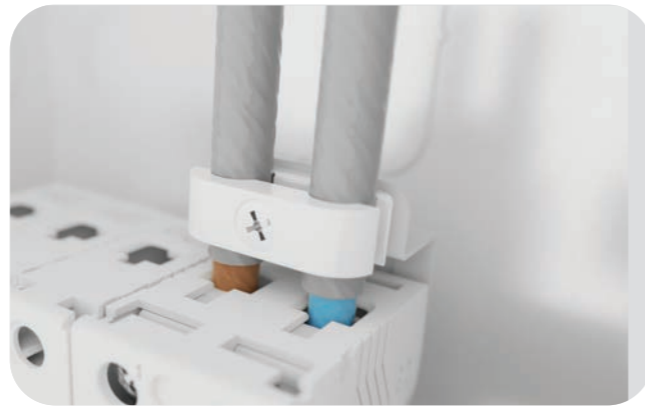

## Mains Switch Tail Clamp

Each consumer and mini unit come supplied and pre-fitted with a Mains Switch Tail Clamp for added stress relief to ensure the Mains Tail terminations do not come loose and to help fix the Mains Switch Isolator more securely to prevent any rocking or movement. The Mains Switch Tail Clamp will accept a maximum of 25mm<sup>2</sup> double insulated tails.



## Variable Knockout Sizes

The units all come supplied with a wide range of 40mm, 32mm, 25mm and 20mm knockouts making each board universally adaptable for all installation and cable types.



## Rear Knockouts

The units also come supplied with rear knockouts to provide ample cabling capacity for any installation type. Each knockout will be supplied with a 0.5M grommet strip to allow a smooth entry into the board, protecting cable from any potential sharp edges.



## Shrouded Live Busbar

Our live busbar comes supplied with the shroud pre-fitted for extra safety and convenience. Our Neutral and Earth Busbars are supplied with backed off screws allowing a faster installation.



## Accessories Pack

Contains a Sticker Set for clear circuit identification and caution warnings, Grommet Knockout Strips, 2 x Blank Modules, a detailed instruction sheet for all recommended installation details and a Live Busbar, Cover and Caps for added insulation and installation completion.

# Take a look inside our Single Phase Boards.



**1 Non-Combustible Enclosures**

Non-combustible and robust metal housings ensure compliance against the third amendment added to the BS 7671 wiring regulations.

**3 Earth and Neutral Bar**

Each unit has its own specifically configured Earth and Neutral Bar to allow for best practice installation of each board type.

**5 Large Space for Wiring**

Each consumer unit has a large space for wiring, suitable for the increasing demands and circuit ways on a consumer unit.

**7 MCB Style Solid Blanks**

These are DIN Rail mountable and can only be removed when the cover is removed, thus providing additional safety. Other types of blanks can easily fall out or become dislodged.

**9 Lock Off Capabilities**

Lockout devices are designed to attach to the moving part of the protective device, usually a switch toggle (rocker switch) which moves from the on to off position.

**2 Torque Rating Label**

There is a handy Torque rating label inside every consumer unit, allowing you to make all terminations with ease.

**4 Grommet Strip**

Each knockout will be supplied with a 0.5m grommet strip to allow a smooth entry into the board, protecting cable from any potential sharp edges.

**6 Keyway DIN Rail**

A fast release Keyway DIN Rail allows for ease of installation.

**8 Enhanced Protection with AFDDs with integrated RCBO**

The smart way to detect arc faults in your circuits.

**10 Compact RCBOs (not shown)**

The latest design in compact RCBOs leaves more than sufficient space for cabling and terminating.

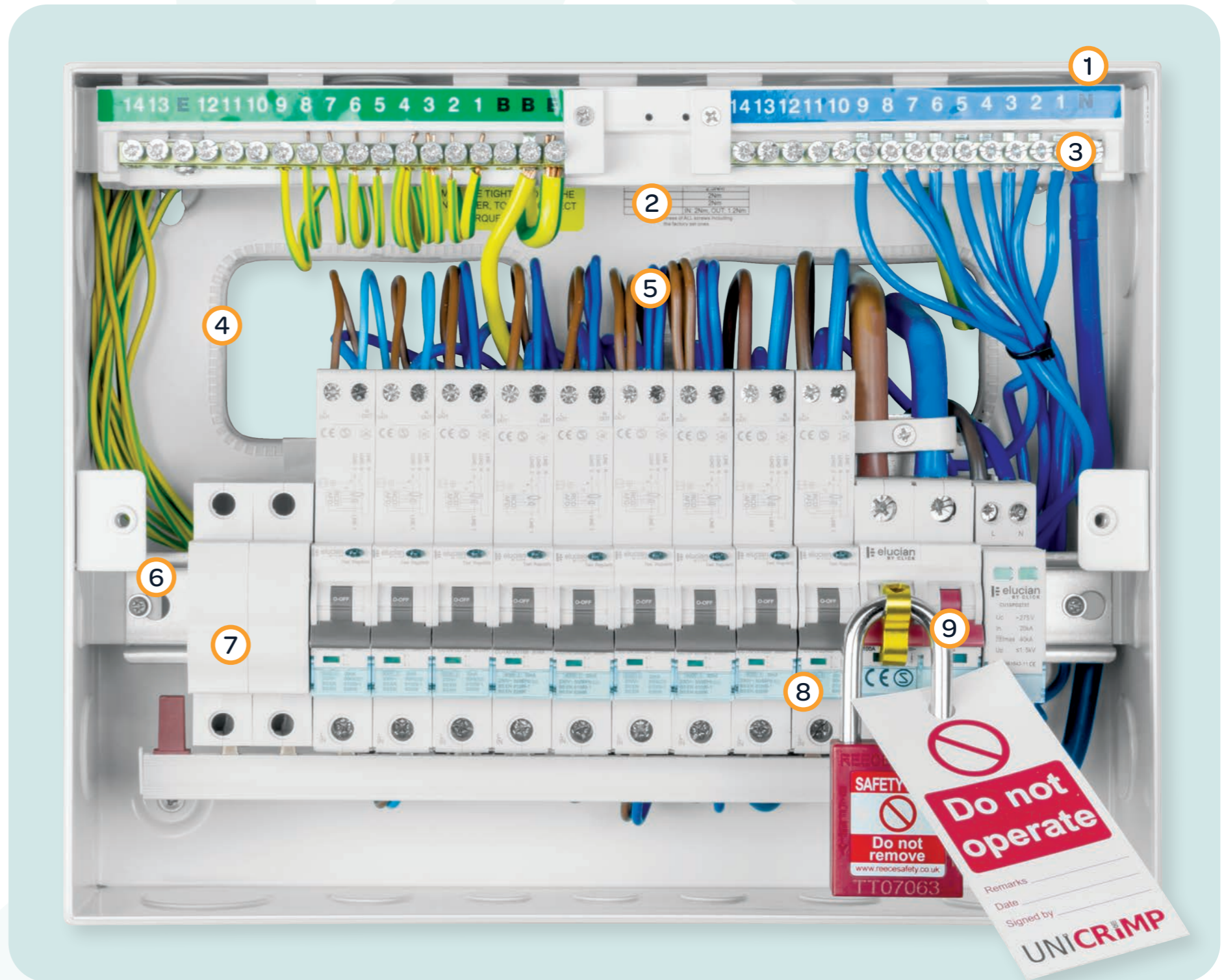



## Unpopulated Consumer Units

A range of unpopulated Elucian® Metal Consumer Units ideal for those projects that need custom configuration without limitations on module placement.



Tail Clamp  
Pre-Installed



\*Example shown - CUEB16

### Terminal Layouts...

5 Way - Neutral & Earth Terminal Configuration



6 Way - Neutral & Earth Terminal Configuration



8 Way - Neutral & Earth Terminal Configuration



10 Way - Neutral & Earth Terminal Configuration



12 Way - Neutral & Earth Terminal Configuration



14 Way - Neutral & Earth Terminal Configuration



16 Way - Neutral & Earth Terminal Configuration



18 Way - Neutral & Earth Terminal Configuration



22 Way - Neutral & Earth Terminal Configuration



Product SKU	Description	Dimensions (mm)
GUEB5	5 Way Unpopulated Metal Garage Unit	168 (W) x 260 (H) x 115 (D)
CUEB6	6 Way Unpopulated Metal Consumer Unit	185 (W) x 260 (H) x 115 (D)
CUEB8	8 Way Unpopulated Metal Consumer Unit	222 (W) x 260 (H) x 115 (D)
CUEB10	10 Way Unpopulated Metal Consumer Unit	258 (W) x 260 (H) x 115 (D)
CUEB12	12 Way Unpopulated Metal Consumer Unit	294 (W) x 260 (H) x 115 (D)
CUEB14	14 Way Unpopulated Metal Consumer Unit	330 (W) x 260 (H) x 115 (D)
CUEB16	16 Way Unpopulated Metal Consumer Unit	366 (W) x 260 (H) x 115 (D)
CUEB18	18 Way Unpopulated Metal Consumer Unit	402 (W) x 260 (H) x 115 (D)
CUEB22	22 Way Unpopulated Metal Consumer Unit	474 (W) x 260 (H) x 115 (D)



## Switch-Disconnecter Units

A range of Elucian® Metal Consumer Units furnished with a 100A Mains Switch.



Straight  
Mains Board



100A  
Mains  
Switch Fitted



Tail Clamp  
Pre-Installed



\*Example shown - CUEB12MS10

### Terminal Layouts...

8 Way - Neutral & Earth Terminal Configuration



10 Way - Neutral & Earth Terminal Configuration



12 Way - Neutral & Earth Terminal Configuration



14 Way - Neutral & Earth Terminal Configuration



16 Way - Neutral & Earth Terminal Configuration



18 Way - Neutral & Earth Terminal Configuration



22 Way - Neutral & Earth Terminal Configuration



Product SKU	Description	Dimensions (mm)
CUEB8MS6	8 Way Unit with 100A Mains Switch (6 Free Ways)	222 (W) x 260 (H) x 115 (D)
CUEB10MS8	10 Way Unit with 100A Mains Switch (8 Free Ways)	258 (W) x 260 (H) x 115 (D)
CUEB12MS10	12 Way Unit with 100A Mains Switch (10 Free Ways)	294 (W) x 260 (H) x 115 (D)
CUEB14MS12	14 Way Unit with 100A Mains Switch (12 Free Ways)	330 (W) x 260 (H) x 115 (D)
CUEB16MS14	16 Way Unit with 100A Mains Switch (14 Free Ways)	366 (W) x 260 (H) x 115 (D)
CUEB18MS16	18 Way Unit with 100A Mains Switch (16 Free Ways)	402 (W) x 260 (H) x 115 (D)
CUEB22MS20	22 Way Unit with 100A Mains Switch (20 Free Ways)	474 (W) x 260 (H) x 115 (D)



## Switch-Disconnecter Units Including Surge Protection

A range of Elucian® Metal Consumer Units furnished with a 100A Mains Switch and a 2 Pole Type 2 275Uc (V-) 40kA SPD.



Straight Mains Board



100A Mains Switch Fitted



Tail Clamp Pre-Installed



SPD Fitted



\*Example shown - CUEB18MSSP15

### Terminal Layouts...

10 Way - Neutral & Earth Terminal Configuration



12 Way - Neutral & Earth Terminal Configuration



14 Way - Neutral & Earth Terminal Configuration



16 Way - Neutral & Earth Terminal Configuration



18 Way - Neutral & Earth Terminal Configuration



22 Way - Neutral & Earth Terminal Configuration



Product SKU	Description	Dimensions (mm)
CUEB10MSSP7	10 Way Unit with 100A Mains Switch & SPD (7 Free Ways)	258 (W) x 260 (H) x 115 (D)
CUEB12MSSP9	12 Way Unit with 100A Mains Switch & SPD (9 Free Ways)	294 (W) x 260 (H) x 115 (D)
CUEB14MSSP11	14 Way Unit with 100A Mains Switch & SPD (11 Free Ways)	330 (W) x 260 (H) x 115 (D)
CUEB16MSSP13	16 Way Unit with 100A Mains Switch & SPD (13 Free Ways)	366 (W) x 260 (H) x 115 (D)
CUEB18MSSP15	18 Way Unit with 100A Mains Switch & SPD (15 Free Ways)	402 (W) x 260 (H) x 115 (D)
CUEB22MSSP19	22 Way Unit with 100A Mains Switch & SPD (19 Free Ways)	474 (W) x 260 (H) x 115 (D)



## REC Unit

A range of Elucian® Metal Rec Units furnished with a 100A Mains Switch and a 2 Pole Type 2 275Uc (V-) 40kA SPD.

100A

Mains  
Switch Fitted



Tail Clamp  
Pre-Installed

SPD

SPD Fitted



### Terminal Layouts...

3 Way - Neutral & Earth Terminal Configuration



Product SKU	Description	Dimensions (mm)
RECEB3MSSP	3 Way Metal REC Unit with 100A Main Switch & SPD	110 (W) x 260 (H) x 115 (D)



## Split Load Units

A range of Elucian® Metal Consumer Units furnished with a 100A Mains Switch and 2 x 80A Type A RCCBs.



Split Load Board



100A Mains Switch Fitted



Tail Clamp Pre-Installed



RCCB Fitted



\*Example shown - CUEB18MSRCD12

## Terminal Layouts...

14 Way - Neutral & Earth Terminal Configuration

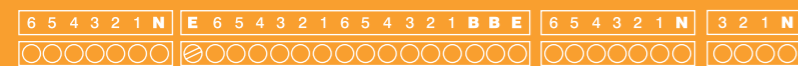

16 Way - Neutral & Earth Terminal Configuration



18 Way - Neutral & Earth Terminal Configuration



22 Way - Neutral & Earth Terminal Configuration

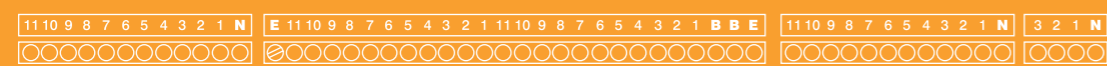

Product SKU	Description	Dimensions (mm)
CUEB14MSRCD8	14 Way Unit with 100A Mains Switch + 2 x 80A 30mA RCCB (4+4 Free Ways)	330 (W) x 260 (H) x 115 (D)
CUEB16MSRCD10	16 Way Unit with 100A Mains Switch + 2 x 80A 30mA RCCB (5+5 Free Ways)	366 (W) x 260 (H) x 115 (D)
CUEB18MSRCD12	18 Way Unit with 100A Mains Switch + 2 x 80A 30mA RCCB (6+6 Free Ways)	402 (W) x 260 (H) x 115 (D)
CUEB22MSRCD16	22 Way Unit with 100A Mains Switch + 2 x 80A 30mA RCCB (8+8 Free Ways)	474 (W) x 260 (H) x 115 (D)



## Split Load Units Including Surge Protection

A range of Elucian® Metal Consumer Units furnished with a 100A Mains Switch, 2 x 80A Type A RCCBs and a 2 Pole Type 2 275Uc (V-) 40kA SPD.



Split Load Board



100A Mains Switch Fitted



Tail Clamp Pre-Installed



RCCB Fitted



SPD Fitted



\*Example shown - CUEB14MSRCDSP6

### Terminal Layouts...

14 Way - Neutral & Earth Terminal Configuration

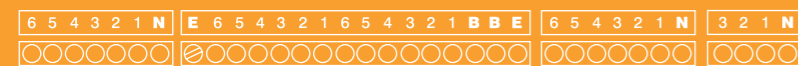

16 Way - Neutral & Earth Terminal Configuration



18 Way - Neutral & Earth Terminal Configuration

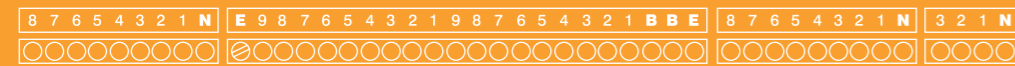

22 Way - Neutral & Earth Terminal Configuration



Product SKU	Description	Dimensions (mm)
CUEB14MSRCDSP6	14 Way Unit with 100A Mains Switch + 2 x 80A 30mA RCCB + 2 Pole SPD (3+3 Free Ways)	330 (W) x 260 (H) x 115 (D)
CUEB16MSRCDSP8	16 Way Unit with 100A Mains Switch + 2 x 80A 30mA RCCB + 2 Pole SPD (4+4 Free Ways)	366 (W) x 260 (H) x 115 (D)
CUEB18MSRCDSP10	18 Way Unit with 100A Mains Switch + 2 x 80A 30mA RCCB + 2 Pole SPD (5+5 Free Ways)	402 (W) x 260 (H) x 115 (D)
CUEB22MSRCDSP14	22 Way Unit with 100A Mains Switch + 2 x 80A 30mA RCCB + 2 Pole SPD (7+7 Free Ways)	474 (W) x 260 (H) x 115 (D)



## Combination Units (High Integrity)

A range of High Integrity Elucian® Metal Consumer Units furnished with a 100A Mains Switch and 2 x 80A Type A RCCBs.



High Integrity Board



Mains Switch Fitted



Tail Clamp Pre-Installed



RCCB Fitted



\*Example shown - CUEHIB18MSRCD12

### Terminal Layouts...

14 Way - Neutral & Earth Terminal Configuration



16 Way - Neutral & Earth Terminal Configuration



18 Way - Neutral & Earth Terminal Configuration



22 Way - Neutral & Earth Terminal Configuration



Product SKU	Description	Dimensions (mm)
CUEHIB14MSRCD8	14 Way Unit with 100A Mains Switch + 2 x 80A RCCB (8 Free Ways)	330 (W) x 260 (H) x 115 (D)
CUEHIB16MSRCD10	16 Way Unit with 100A Mains Switch + 2 x 80A RCCB (10 Free Ways)	366 (W) x 260 (H) x 115 (D)
CUEHIB18MSRCD12	18 Way Unit with 100A Mains Switch + 2 x 80A RCCB (12 Free Ways)	402 (W) x 260 (H) x 115 (D)
CUEHIB22MSRCD16	22 Way Unit with 100A Mains Switch + 2 x 80A RCCB (16 Free Ways)	474 (W) x 260 (H) x 115 (D)



## Combination Units (High Integrity) Including Surge Protection

A range of High Integrity Elucian® Metal Consumer Units furnished with a 100A Mains Switch, 2 x 80A Type A RCCBs and a 2 Pole Type 2 275Uc (V-) 40kA SPD.



High Integrity Board



Mains Switch Fitted



Tail Clamp Pre-Installed



RCCB Fitted



SPD Fitted



\*Example shown - CUEHIB18MSRCDSP10

### Terminal Layouts...

14 Way - Neutral & Earth Terminal Configuration



16 Way - Neutral & Earth Terminal Configuration



18 Way - Neutral & Earth Terminal Configuration



Product SKU	Description	Dimensions (mm)
CUEHIB14MSRCDSP6	14 Way Unit with 100A Mains Switch + 2 x 80A RCCB & SPD (6 Free Ways)	330 (W) x 260 (H) x 115 (D)
CUEHIB16MSRCDSP8	16 Way Unit with 100A Mains Switch + 2 x 80A RCCB & SPD (8 Free Ways)	366 (W) x 260 (H) x 115 (D)
CUEHIB18MSRCDSP10	18 Way Unit with 100A Mains Switch + 2 x 80A RCCB & SPD (10 Free Ways)	402 (W) x 260 (H) x 115 (D)
CUEHIB22MSRCDSP14	22 Way Unit with 100A Mains Switch + 2 x 80A RCCB & SPD (14 Free Ways)	474 (W) x 260 (H) x 115 (D)



## Mini Units (Garage)

A range of Elucian® Metal Consumer Units ideal for garage installations.  
Furnished with either a 100A Mains Switch, 63A Type A RCCB or 80A Type A RCCB.



Tail Clamp  
Pre-Installed



RCCB Fitted



\*Example shown - GUEB5MS3

### Terminal Layouts...

5 Way - Neutral & Earth Terminal Configuration



Product SKU	Description	Dimensions (mm)
GUEB563RCD3	5 Way Unit with 63A 30mA RCCB (3 Free Ways)	168 (W) x 260 (H) x 115 (D)
GUEB580RCD3	5 Way Unit with 80A 30mA RCCB (3 Free Ways)	168 (W) x 260 (H) x 115 (D)
GUEB5MS3	5 Way Unit with 100A Main Switch (3 Free Ways)	168 (W) x 260 (H) x 115 (D)



Keeping you  
in charge...



Functional, stylish,  
and innovative.

## Protection Devices

Our Elucian® range of Protection Devices are easy to install, suitable for residential and light commercial environments, they provide protection against earth faults to ensure people's safety against electrocution and fires.

# Features & Benefits...

# Technical Information...

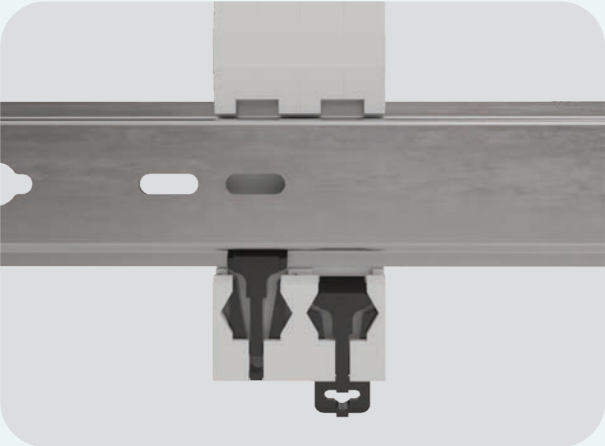

### Clip in Devices

The Elucian® Protection Devices simply click onto the DIN Rail and can be secured with this locking mechanism. This means work can be carried out quicker and without dealing with tight spaces.



### Lock Off Capabilities

Lockout devices (available at Unicrimp®) are designed to attach to the moving part of the protective device, usually a switch toggle (rocker switch) which moves from the on to off position. This ensures the switch cannot be switched back on while work is being carried out.



### Clear Indication

Each protective device has clear and visible trip indication along with clear product information which is easily visible whatever the switch position.



### 3 Year Product Warranty

We take pride in leading the market and our 3 year warranty offers the best peace of mind available as standard today. It reflects the confidence we have in our products and the benefit of years of continuous engineering improvement.



### Visual Status Indicator

Individual cartridge indication; Green: OK; Red: Replace cartridge (Product Ref: CU1SPDC275)



### Green Indicator

SPD cartridge is operating correctly.

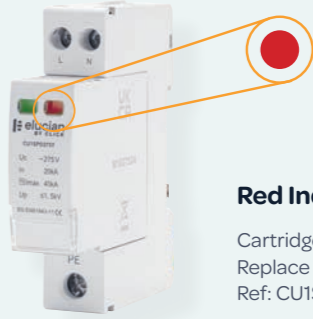

### Red Indicator

Cartridge is at end of life. Replace cartridge (Product Ref: CU1SPDC275)

### Surge Protection

The Type 2, 2 Pole 40kA Surge Protection Device 275Uc (V-) protect all aspects of the installation from an electrical surge, anything from lightning to lightning.

As well as preventing premature aging, destruction of equipment and unnecessary downtime SPDs are recommended to protect sensitive electronic equipment connected to the installation such as computers, televisions, washing machines & LED Lighting.

### Technical Data

- Complies with BS EN 61643-1-11
- Internal overcurrent protection 300A
- Compatible earthing systems TT & TN

### Installation and Connection

- The main protection SPDs are installed directly after the main incoming switch or RCCB.
- Connected in parallel to the equipment to be protected.
- Protection is assured in both common and differential modes.
- Additional overcurrent protection is not required.
- The cartridges are to be removed for insulation resistance testing.

# SPDs

2 Pole 40kA Type 2 18mm Surge Protection Device With Tails

- Double Pole
- Response Time <25ns
- Protection Level (UP) <15kV
- Max Discharge Current 40kA
- 3 Year Warranty
- Large Terminal Capacity



**CU1SPD275T**  
40kA 275Uc (V-) 2 Pole Type 2 SPD with Tails

# Connection Unit

2 Pole 100A Connection Unit

- Double Pole
- 100A Rated
- Large Terminal Capacity
- 3YR 3 Year Warranty



**CU2CN100**  
100A 2 Pole Connection Unit

# RCBO Devices

1 Pole + Neutral True 6kA B Curve & C Curve 30mA Trip RCBOs

- 1 Pole + Neutral
- Trip Current 30mA
- True 6kA
- Type A
- Large Terminal Capacity
- 3YR 3 Year Warranty



## Type A Single Pole B Curve

- CU1RCBO6B**  
6A 30mA B Curve True 6kA RCBO
- CU1RCBO10B**  
10A 30mA B Curve True 6kA RCBO
- CU1RCBO16B**  
16A 30mA B Curve True 6kA RCBO
- CU1RCBO20B**  
20A 30mA B Curve True 6kA RCBO
- CU1RCBO25B**  
25A 30mA B Curve True 6kA RCBO
- CU1RCBO32B**  
32A 30mA B Curve True 6kA RCBO
- CU1RCBO40B**  
40A 30mA B Curve True 6kA RCBO

## Type A Single Pole C Curve

- CU1RCBO6C**  
6A 30mA C Curve True 6kA RCBO
- CU1RCBO10C**  
10A 30mA C Curve True 6kA RCBO
- CU1RCBO16C**  
16A 30mA C Curve True 6kA RCBO
- CU1RCBO20C**  
20A 30mA C Curve True 6kA RCBO
- CU1RCBO25C**  
25A 30mA C Curve True 6kA RCBO
- CU1RCBO32C**  
32A 30mA C Curve True 6kA RCBO
- CU1RCBO40C**  
40A 30mA C Curve True 6kA RCBO

# RCBO Devices

1 Pole + Switched Neutral True 6kA B Curve & C Curve 30mA Trip RCBOs

- 1 Pole + Switched Neutral
- Trip Current 30mA
- True 6kA
- Type A
- Large Terminal Capacity
- 3YR 3 Year Warranty



## Type A Single Pole with Switched Neutral B Curve

- CU1RCBON6B**  
6A 30mA B Curve True 6kA RCBO
- CU1RCBON10B**  
10A 30mA B Curve True 6kA RCBO
- CU1RCBON20B**  
20A 30mA B Curve True 6kA RCBO
- CU1RCBON25B**  
25A 30mA B Curve True 6kA RCBO
- CU1RCBON40B**  
40A 30mA B Curve True 6kA RCBO

## Type A Single Pole with Switched Neutral C Curve

- CU1RCBON6C**  
6A 30mA C Curve True 6kA RCBO
- CU1RCBON10C**  
10A 30mA C Curve True 6kA RCBO
- CU1RCBON16C**  
16A 30mA C Curve True 6kA RCBO
- CU1RCBON20C**  
20A 30mA C Curve True 6kA RCBO
- CU1RCBON25C**  
25A 30mA C Curve True 6kA RCBO
- CU1RCBON32C**  
32A 30mA C Curve True 6kA RCBO
- CU1RCBON40C**  
40A 30mA C Curve True 6kA RCBO
- CU1RCBON45C**  
45A 30mA C Curve True 6kA RCBO

# Bi-Directional RCBO Devices

1 Pole + Switched Neutral True 6kA B Curve  
& C Curve Bi-Directional 30mA Trip RCBOs

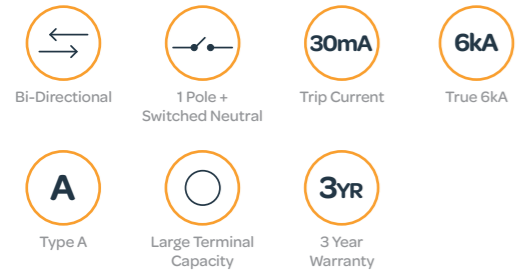

\*Example shown - CU1RCBOD6B Single Pole Switched Neutral B Curve Bi-Directional

# RCBO Devices

Double Pole 2 Module True 6kA B Curve  
& C Curve 30mA Trip RCBOs

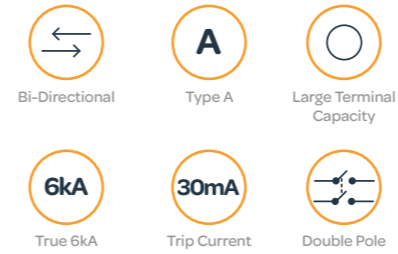

\*Example shown - CU2RCBO45B

## Type A 2 Module Double Pole B Curve

**CU2RCBO45B**  
45A 30mA B Curve True 6kA RCBO

**CU2RCBO50B**  
50A 30mA B Curve True 6kA RCBO

**CU2RCBO63B**  
63A 30mA B Curve True 6kA RCBO

## Type A 2 Module Double Pole C Curve

**CU2RCBO45C**  
45A 30mA C Curve True 6kA RCBO

**CU2RCBO50C**  
50A 30mA C Curve True 6kA RCBO

**CU2RCBO63C**  
63A 30mA C Curve True 6kA RCBO

## Type A Single Pole with Switched Neutral B Curve Bi-Directional

**CU1RCBOD6B**  
6A 30mA B Curve Bi-Directional True 6kA RCBO

**CU1RCBOD10B**  
10A 30mA B Curve Bi-Directional True 6kA RCBO

**CU1RCBOD16B**  
16A 30mA B Curve Bi-Directional True 6kA RCBO

**CU1RCBOD20B**  
20A 30mA B Curve Bi-Directional True 6kA RCBO

**CU1RCBOD25B**  
25A 30mA B Curve Bi-Directional True 6kA RCBO

**CU1RCBOD32B**  
32A 30mA B Curve Bi-Directional True 6kA RCBO

**CU1RCBOD40B**  
40A 30mA B Curve Bi-Directional True 6kA RCBO

**CU1RCBOD45B**  
45A 30mA B Curve Bi-Directional True 6kA RCBO

## Type A Single Pole with Switched Neutral C Curve Bi-Directional

**CU1RCBOD6C**  
6A 30mA C Curve Bi-Directional True 6kA RCBO

**CU1RCBOD10C**  
10A 30mA C Curve Bi-Directional True 6kA RCBO

**CU1RCBOD16C**  
16A 30mA C Curve Bi-Directional True 6kA RCBO

**CU1RCBOD20C**  
20A 30mA C Curve Bi-Directional True 6kA RCBO

**CU1RCBOD25C**  
25A 30mA C Curve Bi-Directional True 6kA RCBO

**CU1RCBOD32C**  
32A 30mA C Curve Bi-Directional True 6kA RCBO

**CU1RCBOD40C**  
40A 30mA C Curve Bi-Directional True 6kA RCBO

**CU1RCBOD45C**  
45A 30mA C Curve Bi-Directional True 6kA RCBO

# Type A - RCCBs



## 2 Pole 30mA Residual Current Circuit Breaker

**CU2RCD63A**  
63A 30mA 2 Pole RCCB

**CU2RCD80A**  
80A 30mA 2 Pole RCCB

**CU2RCD100A**  
100A 30mA 2 Pole RCCB

## Time Delay Residual Current Circuit Breaker

**CU2RCDD63A**  
63A 100mA 2 Pole Time Delay RCCB

**CU2RCDD80A**  
80A 100mA 2 Pole Time Delay RCCB

**CU2RCDD100A**  
100A 100mA 2 Pole Time Delay RCCB



\*Example shown - CU2RCD80A

## Type B - RCCBs

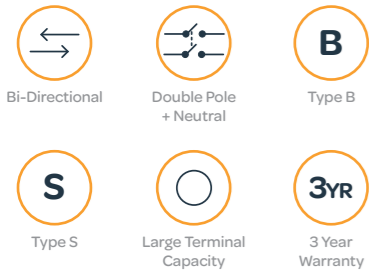

### 2 Pole 30mA Residual Current Circuit Breaker

#### CU3RCD25B

2 Pole 25A 30mA RCCB - Bi-directional

#### CU3RCD40B

2 Pole 40A 30mA RCCB - Bi-directional

#### CU3RCD63B

2 Pole 63A 30mA RCCB - Bi-directional



## Mains Switch-Disconnecter

2 Pole 100A Mains Isolator Switch.

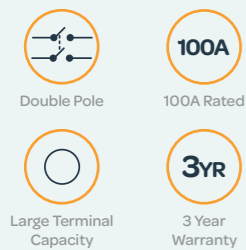

#### CU2MS100

100A 2 Pole Disconnecter-Switch



## AFDD + RCBO

1 Pole True 6kA B & C Curve AFDD + RCBO

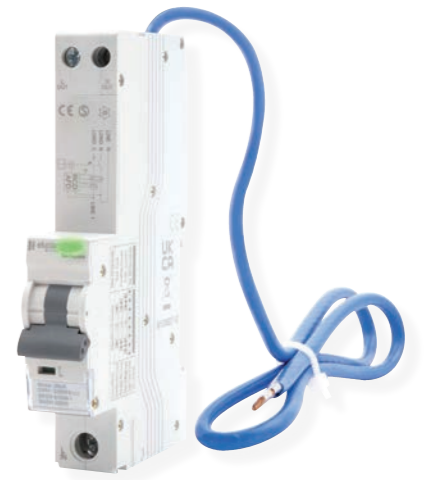

### Type B Curve AFDD & RCBO

#### CU1AFDD6B

1 Pole True 6kA B Curve 6A AFDD & RCBO 30mA

#### CU1AFDD10B

1 Pole True 6kA B Curve 10A AFDD & RCBO 30mA

#### CU1AFDD16B

1 Pole True 6kA B Curve 16A AFDD & RCBO 30mA

#### CU1AFDD20B

1 Pole True 6kA B Curve 20A AFDD & RCBO 30mA

#### CU1AFDD25B

1 Pole True 6kA B Curve 25A AFDD & RCBO 30mA

#### CU1AFDD32B

1 Pole True 6kA B Curve 32A AFDD & RCBO 30mA

#### CU1AFDD40B

1 Pole True 6kA B Curve 40A AFDD & RCBO 30mA

### Type C Curve AFDD & RCBO

#### CU1AFDD6C

1 Pole True 6kA C Curve 6A AFDD & RCBO 30mA

#### CU1AFDD10C

1 Pole True 6kA C Curve 10A AFDD & RCBO 30mA

#### CU1AFDD16C

1 Pole True 6kA C Curve 16A AFDD & RCBO 30mA

#### CU1AFDD20C

1 Pole True 6kA C Curve 20A AFDD & RCBO 30mA

#### CU1AFDD25C

1 Pole True 6kA C Curve 25A AFDD & RCBO 30mA

#### CU1AFDD32C

1 Pole True 6kA C Curve 32A AFDD & RCBO 30mA

#### CU1AFDD40C

1 Pole True 6kA C Curve 40A AFDD & RCBO 30mA

## AFDD + MCB



#### CU1AFMCB32B





1 Pole True 6kA B Curve 32A AFDD & MCB



# MCBs Single Pole

1 Pole, True 6kA B Curve & C Curve MCB Devices.







-  B Curve
-  C Curve
-  Single Pole
-  True 6kA
-  Large Terminal Capacity
-  3 Year Warranty

# Contactors Devices

20A, 25A, 40A or 63A Modular Contactors



-  3 Year Warranty
-  Normally Open
-  Large Terminal Capacity
-  Normally Closed

## Type B Curve

- CU1MCB6B**  
6A B Curve True 6kA MCB
- CU1MCB10B**  
10A B Curve True 6kA MCB
- CU1MCB16B**  
16A B Curve True 6kA MCB
- CU1MCB20B**  
20A B Curve True 6kA MCB
- CU1MCB25B**  
25A B Curve True 6kA MCB
- CU1MCB32B**  
32A B Curve True 6kA MCB
- CU1MCB40B**  
40A B Curve True 6kA MCB
- CU1MCB50B**  
50A B Curve True 6kA MCB
- CU1MCB63B**  
63A B Curve True 6kA MCB

## Type C Curve

- CU1MCB6C**  
6A C Curve True 6kA MCB
- CU1MCB10C**  
10A C Curve True 6kA MCB
- CU1MCB16C**  
16A C Curve True 6kA MCB
- CU1MCB20C**  
20A C Curve True 6kA MCB
- CU1MCB25C**  
25A C Curve True 6kA MCB
- CU1MCB32C**  
32A C Curve True 6kA MCB
- CU1MCB40C**  
40A C Curve True 6kA MCB
- CU1MCB50C**  
50A C Curve True 6kA MCB
- CU1MCB63C**  
63A C Curve True 6kA MCB

## 2 Pole 20A Modular Contactors (1 Module)

- MC20220**  
2 Pole 1 Module 20A Contactor, 2 x Normally Open Contacts
- MC20202**  
2 Pole 1 Module 20A Contactor, 2 x Normally Closed Contacts
- MC20211**  
2 Pole 1 Module 20A Contactor, 1 x Normally Open, 1 x Normally Closed Contacts

## 4 Pole 25A Modular Contactors (2 Module)

- MC25440**  
4 Pole 2 Module 25A Contactor, 4 x Normally Open Contacts
- MC25404**  
4 Pole 2 Module 25A Contactor, 4 x Normally Closed Contacts
- MC25422**  
4 Pole 2 Module 25A Contactor, 2 x Normally Open, 2 x Normally Closed Contacts
- MC25431**  
4 Pole 2 Module 25A Contactor, 3 x Normally Open, 1 x Normally Closed Contacts

## 4 Pole 40A Modular Contactors (3 Module)

- MC40440**  
4 Pole 3 Module 40A Contactor, 4 x Normally Open Contacts
- MC40404**  
4 Pole 3 Module 40A Contactor, 4 x Normally Closed Contacts
- MC40422**  
4 Pole 3 Module 40A Contactor, 2 x Normally Open, 2 x Normally Closed Contacts
- MC40431**  
4 Pole 3 Module 40A Contactor, 3 x Normally Open, 1 x Normally Closed Contacts

## 4 Pole 63A Modular Contactors (3 Module)

- MC63440**  
4 Pole 3 Module 63A Contactor, 4 x Normally Open Contacts
- MC63404**  
4 Pole 3 Module 63A Contactor, 4 x Normally Closed Contacts
- MC63422**  
4 Pole 3 Module 63A Contactor, 2 x Normally Open, 2 x Normally Closed Contacts
- MC63431**  
4 Pole 3 Module 63A Contactor, 3 x Normally Open, 1 x Normally Closed Contacts

# Energy Meters

100A Single Phase Modbus Multifunction Meter

100A

100A Rated

3YR

3 Year  
Warranty

CU2EMID

100A Single Phase Modbus Multifunction Energy Meter



# Fused Main Switch

80A & 100A Fused Main Switches

80A

HRC Fuse  
Supplied

Available in...

DB700

80A Fused Main Switch (80A HRC Fuse Fitted)

DB701

80A Fused Main Switch (80A HRC Fuse Fitted) - Lockable

DB750

100A Fused Main Switch (80A HRC Fuse Fitted)

DB751

100A Fused Main Switch (80A HRC Fuse Fitted) - Lockable

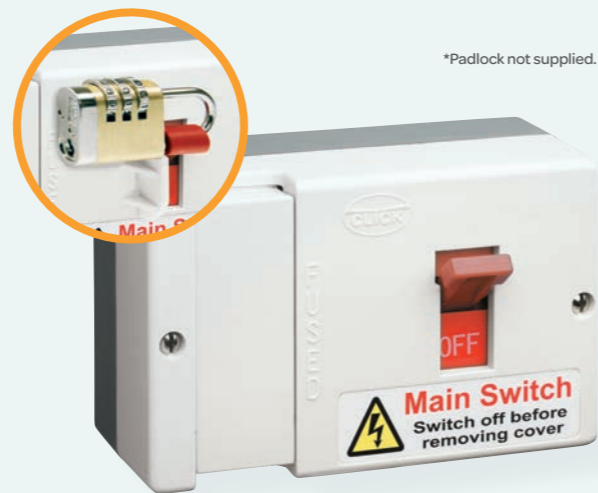

# Elucian® Accessories...

## Fused Main Switch Accessories

Product SKU Description

DB790 Metal Enclosure for Fused Main Switch (DB700/701)  
\*Suitable for DB700/701 80A fused main switch

DB791 Metal Enclosure for Fused Main Switch (DB750/751)  
\*Suitable for DB701/751 100A fused main switch

DB981 Elongated Cable Shroud (Packaged Individually)  
\*Enables surface and rear entry cable access  
\*Suitable for 35mm<sup>2</sup> cables



## Terminal Bars

Product SKU Description

CUTB4 4 Way Terminal Bar

CUTB6 6 Way Terminal Bar

CUTB7 7 Way Terminal Bar

CUTB8 8 Way Terminal Bar

CUTB9 9 Way Terminal Bar

CUTB10 10 Way Terminal Bar

CUTB12 12 Way Terminal Bar

CUTB15 15 Way Terminal Bar

CUTB16 16 Way Terminal Bar

CUTB17 17 Way Terminal Bar

CUTB18 18 Way Terminal Bar

CUTB19 19 Way Terminal Bar

CUTB20 20 Way Terminal Bar

CUTB22 22 Way Terminal Bar

CUTB23 23 Way Terminal Bar

CUTB26 26 Way Terminal Bar

CUTBSC Terminal Bar Support Clip & Screws (PK5)

CUTBSCSL Split Load Terminal Bar Support Clip & Screws (PK 5)

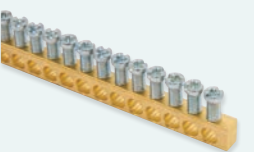
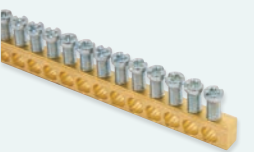

# Blank Modules

Single way Din Rail Blank Module.

3YR

3 Year  
Warranty

CU1BLANK

Single Way Din Rail Blank Module



### Busbar & Cover Sets

Product SKU	Description
CUBUS3	3 Way Busbar & Cover Set
CUBUS4	4 Way Busbar & Cover Set
CUBUS5	5 Way Busbar & Cover Set
CUBUS6	6 Way Busbar & Cover Set
CUBUS7	7 Way Busbar & Cover Set
CUBUS8	8 Way Busbar & Cover Set
CUBUS12	12 Way Busbar & Cover Set
CUBUS20	20 Way Busbar & Cover Set
CUCAP	Busbar Caps (PK 10)

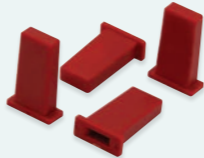
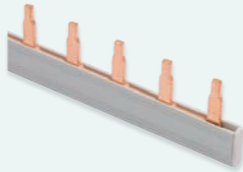
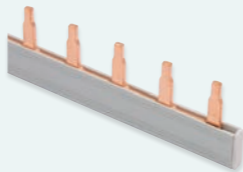

### DIN Rails

Product SKU	Description
CUDR10	10 Way DIN Rail
CUDR12	12 Way DIN Rail
CUDR14	14 Way DIN Rail
CUDR16	16 Way DIN Rail
CUDR18	18 Way DIN Rail
CUDR22	22 Way DIN Rail

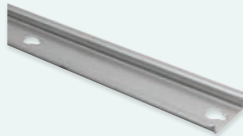

### SPD Cartridge

Product SKU	Description
CU1SPDC275	18mm 275V- 40kA SPD Cartridge
CU2SPDC275	36mm 275V- 40kA SPD Cartridge <small>*Replacement for both live and neutral sides</small>



### Link Cables

Product SKU	Description
CUCNL210	Neutral Link Cable (210mm)
CUCNL285	Neutral Link Cable (285mm)
CUCNL325	Neutral Link Cable (325mm)
CUCNL385	Neutral Link Cable (385mm)
CUCNL410	Neutral Link Cable (410mm)
CUCLL	Combined Live Link Cable (285mm & 355mm)



### Grommet Strip

Product SKU	Description
CUGS1	500mm Grommet Strip (PK 3)



## Mains Cable Clamp Components

Product SKU	Description
CUCLAMP	Mains Cable Clamp & Screw
CUPLATE	Mains Cable Clamp Plate



## Retrofit Locking Device

Product SKU	Description
CUELOCK	Retrofit Locking Device



\*Can be installed on the left or right of the enclosure.  
\*Padlock not supplied.  
UK Patent: GB 2115573.4, Irish Patent: 87573

## Adhesive Labels

Product SKU	Description
CULAB1	Set of Adhesive Labels



## Pattress Mount

Product SKU	Description
CUEBPM	Consumer Unit Pattress Mount



## Flush Lid

Product SKU	Description
CUEB16FL	Flush Lid (16 Way Consumer Units)
CUEB18FL	Flush Lid (18 Way Consumer Units)
CUEB22FL	Flush Lid (22 Way Consumer Units)



## Recess Frames

Product SKU	Description
CUEBRF16	16 Way Consumer Unit Recessed Frame
CUEBRF18	18 Way Consumer Unit Recessed Frame
CUEBRF22	22 Way Consumer Unit Recessed Frame



## Cable Entry Plate

Product SKU	Description
CUCEPL	Knockout Cable Entry Plate - Large (PK 5)
CUCEPS	Knockout Cable Entry Plate - Small (PK 5)

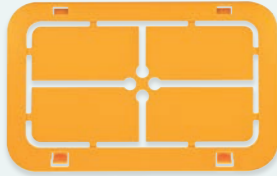

# Complete the installation...

## We've Got You Covered

The Unicrimp® range includes cable ties, crimp terminals, PVC tape, copper tube terminals, cable clips, brass/nylon glands, tail glands and earth sleeving – providing everything required to harness cable between the consumer unit and the end accessory.

Helps to provide compliance with Regulation 522.8.5.



**UNICRIMP®**

## Cable & Wire Accessories.

Explore our extensive range of cable management consumables. All our products are manufactured under stringent quality control systems and are fully compliant with the very latest industry regulations.



**Q-CRIMP®**

## Fire-Rated Accessories

Don't get caught out by the latest regs! Explore our range of fire rated products and prevent cables from premature collapse during a fire and keep emergency services and the public safe.

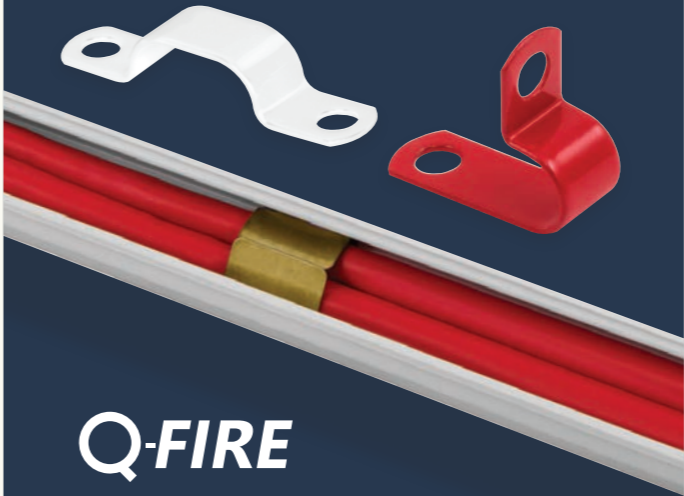

**Q-FIRE**

## Lever Connectors & Connection Boxes

Focusing on strong, quick and reliable solutions, the new Q-Nect range offers great versatility for electrical connections. Each product is packed with features which makes your installations quicker and easier.



**Q-NECT**

## The No.1 Sealant & Adhesives

The No.1 hybrid sealant and adhesive. OB1 bonds and seals a range of materials, works in damp conditions and even under water. User-friendly, hybrid polymer formulation for the ultimate in bonding and sealing.



**OB1** MULTI-SURFACE CONSTRUCTION SEALANT & ADHESIVE

# Complete the installation...

## Bluetooth DIN Rail Time Switches

Bluetooth is a wireless communication protocol that allows programming of the switch using the free APP available on Android and IOS smart phones and tablets. This works the same way as contactless bank cards, oyster travel cards and mobile payment systems. The program is setup on the APP and transfers to the switch when the smart device is held in close proximity.

## NFC DIN Rail Time Switches

NFC (Near Field Communication) is a wireless communication protocol that allows you to program the switch using the free Sangamo Connect app on an Android NFC Smart phone.

This works the same way as contactless bank cards, oyster travel cards and mobile payment systems. You set the program up on the app and hold the phone next to the switch to read, write or transfer programming times.

## DIN Rail Time Switches

All Sangamo's DIN Rail mountable time switches are designed for 35mm "Top Hat" rail. Switches come in 1, 2 or 4 modules, each module is 17.5mm wide, which fits the required width in the DIN enclosure.

Using the 25195 USB Hub and Easy Vue software or 25196 USB Hub with bluetooth and connect app programs can be transferred to a 25193 data key and then to one or multiple switches. 1 module switches do not require a Data Key as the fascia can be removed and slotted into the Hub directly.



## NFC DIN Rail Time Switches



### 72113NFC

Standard NFC 2 Module 1 Channel, 7 Day, 56 Operations

### 72102NFC

Astro NFC Module 1 Channel, 24HR Timer, 4 Operations

### 72103NFC

Astro NFC 2 Module 1 Channel, 7 Day, 56 Operations

## Bluetooth DIN Rail Time Switches



### SC2811PRO4

Standard Bluetooth 2 Module 1 Channel, 7 Day, 100 Operations

### SC2813PRO4

Astro Bluetooth 2 Module 1 Channel, 7 Day, 100 Operations

### SC2823PRO4

Astro Bluetooth 2 Module 2 Channel, 7 Day, 100 Operations

## DIN Rail Time Switches



### 71111

Standard 1 Module 1 Channel, 7 Day, 46 Operations

### 72112

Standard 2 Module 1 Channel, 7 Day, 46 Operations

### 25162

Standard 2 Module 1 Channel, Yearly, 300 Operations

### 26404

Standard 4 Module 4 Channel, 7 Day, 300 Operations

### 11002

Standard 1 Module 24HR Timer

### 71101

Astro 1 Module 1 Channel, 7 Day, 60 Operations

### 72101

Astro 2 Module 1 Channel, 7 Day, 60 Operations

### 72201

Astro 2 Module 2 Channel, 7 Day, 60 Operations

# Three Phase Distribution Boards and Circuit Protection Devices.

## Three Phase Brochure

Check out our Three Phase Distribution brochure and explore our huge range of Metal Distribution Boards, Circuit Protection Devices and accessories.



\*Scan the QR code to view our Three Phase brochure.

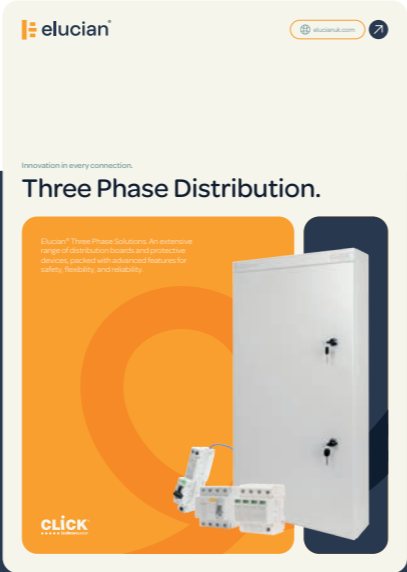

## Metal Distribution Boards.

Elucian® offers a versatile range of Three Phase Metal Distribution Boards designed to suit a wide variety of installations, these boards are packed with features that enhance convenience, flexibility, and safety.

- 125A Incomer 4 & 6 Way Boards
- 125A or 250A Incomer 8, 12, 16, 20 & 24 Way Boards



[elucianuk.com](http://elucianuk.com)



## Circuit Protection Devices.

Our Elucian® range of Protection Devices are easy to install, suitable for commercial and industrial environments, they provide protection against earth faults to ensure people's safety against electrocution and fires.

### Main Incomers

- Mains Isolator Switch
- RCCBs (Type A & B)
- Fused Main Switch

### Protection Devices

- RCBO (B & C Curve)
- AFDD (B & C Curve)
- AFDD + MCB
- 1 & 3 Pole MCBs
- SPD & Cartridges
- Energy Meter Kits
- Blank Modules

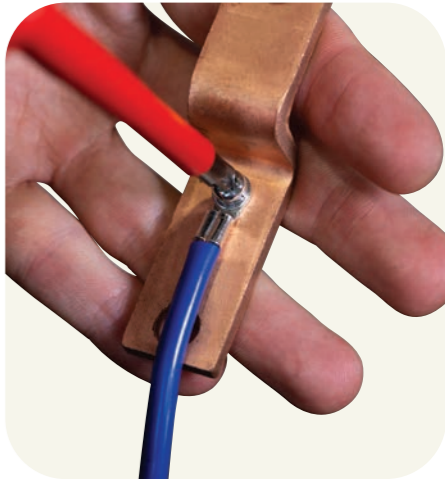

## Spares & Accessories.

The Elucian® range offers a wide variety of compatible accessories, including cable entry plates and pattress mounts, to make any installation easier and faster.

- Extension Boards
- Three Phase to Single Phase Converter
- Isolator Locking Kit
- RCD Link Kit
- Gland Plates
- Blank Plates
- Busbar Caps
- Synthetic Bonded Resin Paper
- Label Packs



# More from the Scolmore® Group.

## Wiring Accessories.

Click Scolmore® is one of the UK's leading manufacturers of electrical accessories. The company is proud to be a British-based, family-run business with an international reputation for quality, innovation and exemplary customer service.



**CLICK**  
ScolmoreGROUP

## Lighting Solutions.

The comprehensive collection of lighting products from Ovia® will provide solutions for a whole spectrum of projects in a broad variety of sectors, including domestic, commercial, industrial, utility, amenity, emergency lighting and floodlighting.



**OVI**  
ScolmoreGROUP

## Cable & Wiring Accessories.

Unicrimp offers a comprehensive range of cable accessories under the Q-crimp, Q-Fire, and Q-Nect brands, exclusively for the electrical trade. All products meet strict quality standards and comply with the latest regulations.



- Cable Ties
- Crimp Terminals
- PVC Tape
- Copper Tube Terminals
- Cable Clips
- Brass & Nylon Glands
- Tail Glands
- Earth Sleeving

Helps to provide compliance with Regulation 522.8.5.

**UNICRIMP**  
ScolmoreGROUP

## Fire & Security Products.

ESP is a leading supplier of electronic security and fire protection products, including Smart Security, CCTV, Access Control, Fire Protection, Emergency Lighting, and Sangamo Time Switches and Heating Controls.

**ESP**  
ScolmoreGROUP



## No.1 Sealant and Adhesives.

The No.1 hybrid sealant and adhesive. OB1 bonds and seals a range of materials, works in damp conditions and even under water. User-friendly, hybrid polymer formulation for the ultimate in bonding and sealing.



**OB1**  
MULTI-SURFACE CONSTRUCTION SEALANT & ADHESIVE

United Kingdom



Scolmore House, Mariner,  
Lichfield Road Industrial Estate  
Tamworth, Staffordshire, B79 7UL

+44 (0) 1827 63454  
sales@scolmore.com  
www.scolmore.com



Southern Ireland



18 Corrig Road,  
Sandyford Industrial Estate,  
Dublin, D18 WV79, Ireland

+353 (1) 2811 122  
sales@clicklitehouse.ie  
www.clicklitehouse.ie



Scolmore® Middle East



Lake Central Tower,  
Office 1803, Business Bay,  
Dubai, UAE

+971 4589 6552  
sales@scolmoreme.com  
www.scolmoreme.com

