

Innovation in every connection.

Three Phase Distribution Issue 2

Elucian® Three Phase solutions. An extensive range of distribution boards and protective devices, packed with advanced features for safety, flexibility, and reliability.



Crafted with installers in mind, Elucian® by Click® presents a versatile range of Three Phase Metal Distribution Boards. Designed to suit a wide variety of installations, these boards are packed with features that enhance convenience, flexibility, and safety.



- 03 Our Promise
- 05 Keeping up with the Regs
- 07 Safeguard your installations with Surge Protection
- 09 Increase protection with AFDDs
- 12 Power & Lighting Distribution Boards.
- 13 Three Phase Distribution Boards
- 25 Three Phase Circuit Protection Devices
- 42 Three Phase Extension Boards & Enclosures
- 43 Three Phase Spares & Accessories
- 47 Single Phase Consumer Units & Devices

Reliable Distribution Boards & Circuit Protection for safe and easy installations.



Precision manufacturing for reliability and safety.

Safety First 

At Elucian®, precision manufacturing is at the core of our commitment to reliability and safety. Our Three Phase Distribution Boards are meticulously designed and engineered to deliver consistent, high-performance results, making them a trusted choice for professionals. Each board undergoes rigorous testing to meet and exceed BS EN 61439-3 standards, ensuring compliance with safety, durability, and functionality requirements. This thorough process guarantees that our products provide dependable, long-lasting solutions for even the most demanding electrical installations, offering peace of mind to installers and end-users alike.

Unbeatable Quality 

Uncompromising quality you can trust.

Elucian® products are crafted with a commitment to exceptional quality. We use only the finest materials and subject every product to rigorous testing to ensure they meet and exceed industry standards. This dedication to excellence guarantees reliable, durable, and safe solutions for all your electrical installations.

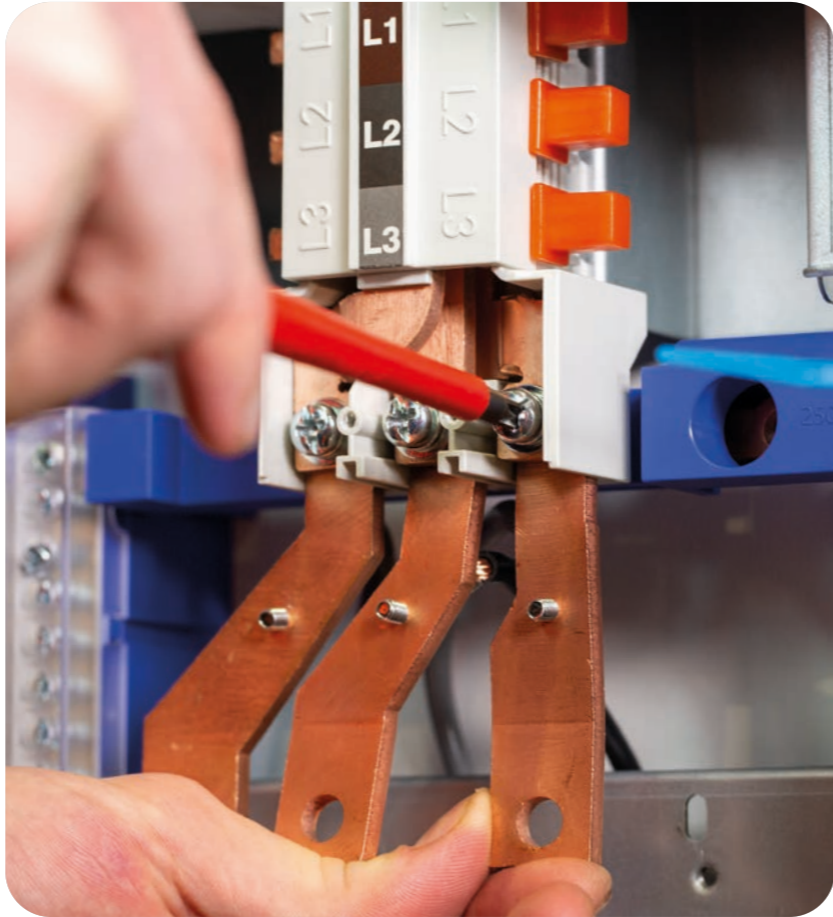

Endless Support 

Technical support when you need it.

Our in-house Scolmore® Group technical support team is here to assist with all your Three Phase queries, offering expert advice and guidance. For additional information and support, visit our website to access helpful resources and solutions.



The Elucian® consumer units range has been designed to ensure compliance with BS 7671.

Our engineers have considered how installers need to comply with the UK wiring regulations when installing distribution boards in buildings across the UK. The Elucian® Three Phase range has comprehensive options for every installation. These consist of distribution boards, extension boards, circuit protection devices, energy meters and accessories.

Explore Single Phase

Explore our full range of Single Phase Consumer Units, Circuit Protection Devices and accessories.

Single Phase on [Page 47](#)

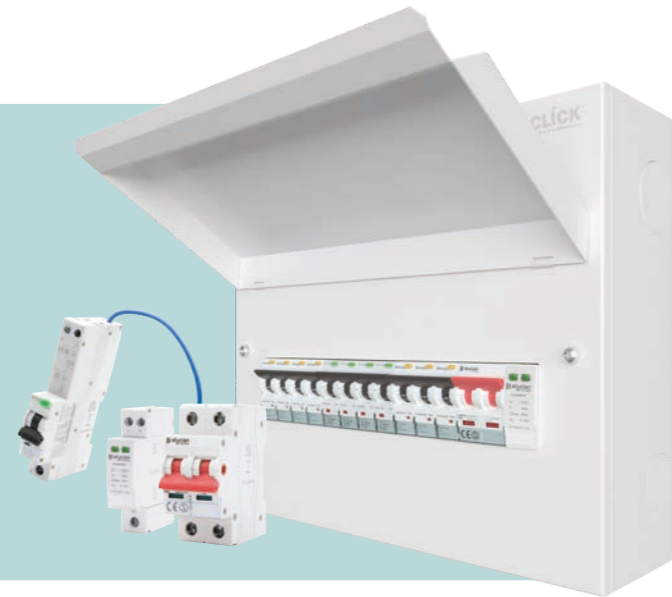

Overload Protection

(536.4.3.2) & (536.4.202)

RCCBs are not designed to withstand overload currents, so careful consideration must be given to the expected load of the final circuits.

To ensure proper protection, designers and installers must select an appropriately rated RCCB from the available options: 63A, 80A, or 100A.

Please ensure the chosen device aligns with the specific requirements of the installation.

Types of RCD

(531.3.3)

Many different types of RCD exist. BS 7671 recognises Types AC, A, F and B. Currently AC RCDs are recognised as acceptable for general purpose. However, if the installation has any DC components or frequency alterations due to connected loads one of the other types must be selected.

As most installations in the UK now have some DC components, Type A RCDs are the basic type of device selected for use.

Where higher frequencies exist, or where larger DC components exist, Type F or Type B RCDs should be selected for use. Furthermore, there are several specific requirements in BS 7671 where either Type F or Type B devices are necessary.

Overvoltage Protection

(Section 443) & (Section 534)

Surge Protection Devices (SPDs) provide effective defence against overvoltage.

Section 443

Outlines the requirements for protecting against transient overvoltages caused by atmospheric conditions or switching operations when selecting SPDs for the electrical system.

Section 534

Specifies the provisions for selecting and using SPDs within the electrical system.

Our Type 1&2 SPD offers protection against man-made overvoltages and lightning strokes near the installation.

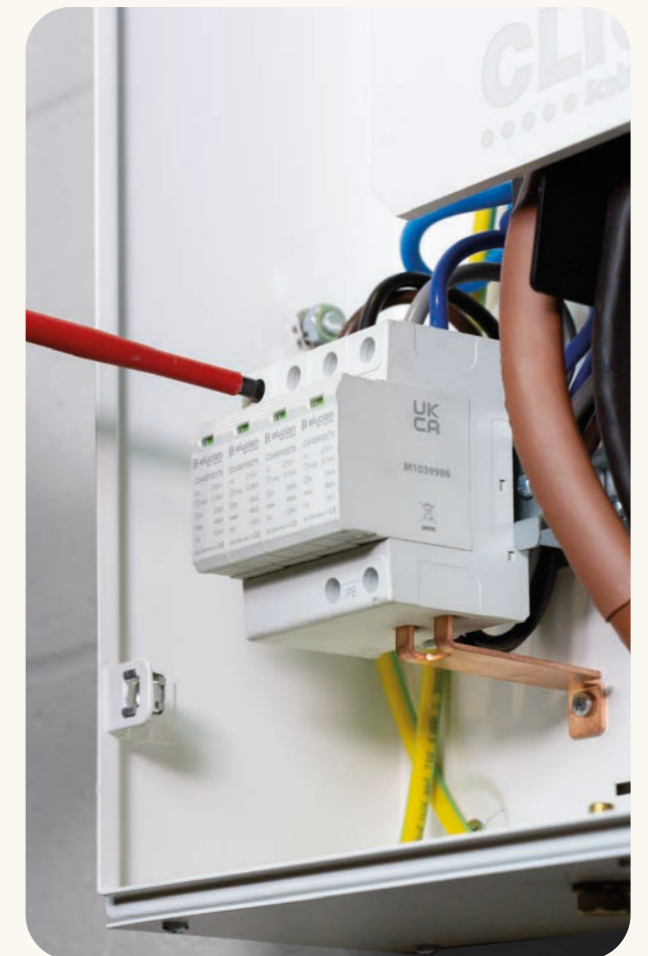

Safeguard your installations with Surge Protection.

I_{imp} – Impulse current of 10/350 μ s waveform.

I_n – Surge current of 8/20 μ s waveform associated with Type 2 SPDs.

U_p - The residual voltage that is measured across the terminal of the SPD when I_n is applied.

U_c - The maximum voltage which may be continuously applied to the SPD without it conducting.

I_{max} - Maximum short circuit current of the device.

Full SPD Listing on **Page 32**



Transient Overvoltages

Many installations across the UK have electronic components within them. Surge protection will offer those devices and appliances protection from overvoltage.

Products such as computers, printers, flat screen televisions, alarms, microwaves and washing machines are commonplace. These can all be vulnerable to transient overvoltages, which can significantly reduce the equipment's lifespan through degradation and damage.

A transient over voltage or surge is a short duration increase in voltage measured between two or more conductors. In short, this means anything from microseconds (millionths of a second) to a few milliseconds (thousandths of a second) in duration.

Covers Overvoltage Control (443.4.1 & 443.4.2)

Protection against overvoltages shall be provided where the consequence caused by overvoltage could:

- (i) Result in serious injury to, or loss of, human life,
- (ii) Significant financial or data loss.

For all other cases, protection against transient overvoltages shall be provided unless the owner of the installation declares it is not required due to any loss or damage being tolerable and they accept the risk of damage to equipment and any consequential loss.

Protection against overvoltages shall be considered in the case of equipment likely to produce switching overvoltages or disturbances exceeding the values according to the voltage category of the installation, e.g. where an LV generator supplies the installation or where inductive or capacitive loads (e.g. motors, transformers, capacitor banks) storage units or high-current loads are installed.



Type 1+2 & 2 SPDs

We offer a range of Type 1+2 and 2 Surge Protective Devices designed to safeguard electrical systems from transient overvoltages caused by lightning strokes and power surges. These devices ensure reliable protection for both residential and commercial installations.

SPD listing on **Page 32**



Bespoke Three Phase Distribution Boards.

Our bespoke Three Phase Distribution Boards offer the freedom to create a power distribution solution tailored to your needs. Built with high-quality Elucian® products and designed by our in-house team of experts, we ensure a reliable, custom-built board to meet your exact requirements.

Product SKU	Product Description
TPEB0404-1V	4+4 Way 125A Three Phase Power and Lighting Distribution Boards - Vertical Mount
TPEB0406-1V	4+6 Way 125A Three Phase Power and Lighting Distribution Boards - Vertical Mount
TPEB0416-1V	4+16 Way 125A Three Phase Power and Lighting Distribution Boards - Vertical Mount
TPEB0604-1V	6+4 Way 125A Three Phase Power and Lighting Distribution Boards - Vertical Mount
TPEB0606-1V	6+6 Way 125A Three Phase Power and Lighting Distribution Boards - Vertical Mount
TPEB0608-1V	6+8 Way 125A Three Phase Power and Lighting Distribution Boards - Vertical Mount
TPEB0804-1V	8+4 Way 125A Three Phase Power and Lighting Distribution Boards - Vertical Mount
TPEB0806-1V	8+6 Way 125A Three Phase Power and Lighting Distribution Boards - Vertical Mount
TPEB0808-1V	8+8 Way 125A Three Phase Power and Lighting Distribution Boards - Vertical Mount
TPEB0812-1V	8+12 Way 125A Three Phase Power and Lighting Distribution Boards - Vertical Mount
TPEB1204-1V	12+4 Way 125A Three Phase Power and Lighting Distribution Boards - Vertical Mount
TPEB1206-1V	12+6 Way 125A Three Phase Power and Lighting Distribution Boards - Vertical Mount

*All boards listed above come pre fitted with an energy meter and type 2 surge protection, none surge options are available.

Product SKU	Product Description
TPEB1208-1V	12+8 Way 125A Three Phase Power and Lighting Distribution Boards - Vertical Mount
TPEB1212-1V	12+12 Way 125A Three Phase Power and Lighting Distribution Boards - Vertical Mount
TPEB1604-1V	16+4 Way 125A Three Phase Power and Lighting Distribution Boards - Vertical Mount
TPEB1606-1V	16+6 Way 125A Three Phase Power and Lighting Distribution Boards - Vertical Mount
TPEB1608-1V	16+8 Way 125A Three Phase Power and Lighting Distribution Boards - Vertical Mount
TPEB1612-1V	16+12 Way 125A Three Phase Power and Lighting Distribution Boards - Vertical Mount
TPEB1616-1V	16+16 Way 125A Three Phase Power and Lighting Distribution Boards - Vertical Mount
TPEB2004-1V	20+4 Way 125A Three Phase Power and Lighting Distribution Boards - Vertical Mount
TPEB2006-1V	20+6 Way 125A Three Phase Power and Lighting Distribution Boards - Vertical Mount
TPEB2008-1V	20+8 Way 125A Three Phase Power and Lighting Distribution Boards - Vertical Mount
TPEB2012-1V	20+12 Way 125A Three Phase Power and Lighting Distribution Boards - Vertical Mount

Require a Custom Board?

To request a custom Three Phase Distribution Board, simply email us at the address below. Our design team will get in touch with you to discuss your specific requirements and create a tailored solution that meets your needs.

bespoke@elucianuk.com



Power & Lighting Distribution Boards.

Our power and lighting boards are designed with efficiency in mind, featuring a built-in Energy Meter for accurate tracking. Each board is supplied with a pre-installed main incoming device and SPD, ensuring a seamless installation process while offering reliable and efficient energy management.

www.elucianuk.com



Three Phase Distribution Boards.

Our Three Phase Distribution Boards are designed to deliver reliable performance, safety, and flexibility for commercial and industrial installations. Built to meet the demands of modern electrical systems, our boards feature advanced protective devices and robust construction, ensuring compliance with industry standards. With a range of sizes and configurations, they provide a versatile solution for managing complex power distribution needs.

Tested to BS EN 64139-3

Elucian® Three Phase Distribution Boards are rigorously tested to meet BS EN 61439-3 standards, ensuring they comply with strict safety, performance, and reliability requirements.

This certification guarantees that our boards can handle the demands of modern electrical systems while providing peace of mind to installers and end-users. Meeting these standards is vital as it ensures the products are safe, durable, and fit for purpose in a wide range of applications.

Distribution Boards on **Page 19**



Typical Applications

Three Phase Distribution Boards are commonly used in commercial, industrial, and large residential applications to manage and distribute power efficiently. Typical uses include powering HVAC systems, machinery, lighting circuits, critical equipment, and large-scale general power requirements. Their robust design makes them ideal for installations requiring high performance, reliability, and compliance with demanding electrical standards.



Power and protection. All the benefits of Three Phase Distribution Boards.



RCCB, 125A Isolator or 250A Isolator

Our 8, 12, 16, 20, and 24-way boards offer versatile configurations, allowing you to choose between any of our RCCBs, 125A Isolator, or 250A Isolator to suit your installation needs.

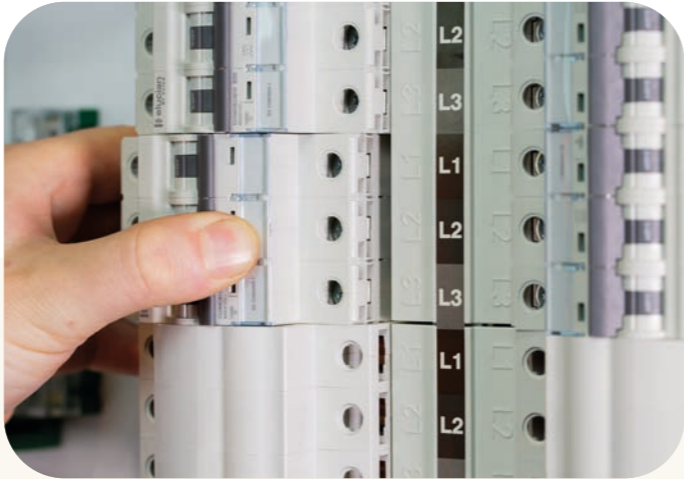

Device Alignment

We've carefully designed our boards to maintain device alignment when fully installed, ensuring a neat and organized appearance. This also allows for easy fitting of the cover.



Quick Release Doors

The doors are fitted with spring clips, making them quick and easy to remove. This design also allows the doors to be re-fitted on the opposite side, providing ultimate flexibility.



Ventilation Slots

All our boards are designed with ventilation slots at the top and bottom, ensuring proper airflow to prevent overheating and maintain optimal performance.



Trunking Entry

Our Three Phase Distribution Boards are designed for convenience, featuring removable panels at both the top and bottom to provide unobstructed cable entry for versatile installations.



SPD Installation

Our SPDs are designed for seamless integration, allowing installation directly within our Distribution Boards without additional enclosures. Replaceable SPD cartridges are also available for all of our SPDs.



Stacked Boards

Our boards are designed for easy stacking, allowing multiple units to be stacked on top of each other. You can also stack a Single Phase 18-way extension board, providing flexible solutions for larger installations.

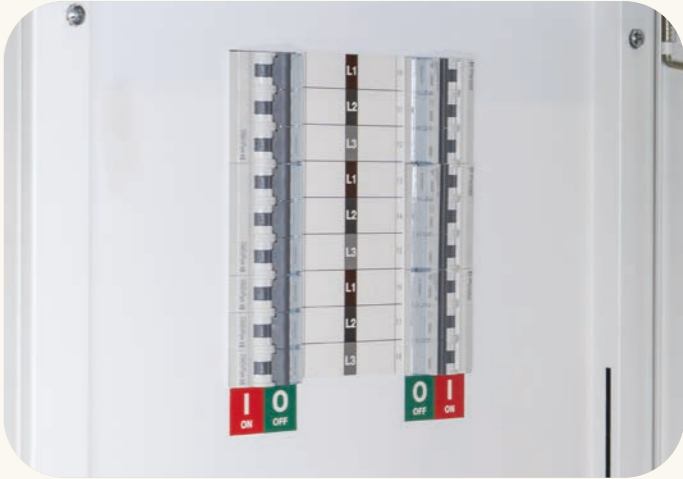

Front Cover Alignment

The front cover is thoughtfully designed to ensure precise alignment of cut-outs and knock-outs with the devices, reducing the risk of accidentally pressing the 'test' button on a switch.

Take a look inside our Three Phase boards.

Example 6 Way Distribution Board

1



Cable Tie Mounts
Our boards feature integrated cable tie mounts on the back, providing a secure and durable solution for cable management, ensuring a neat and long-lasting installation.

2



Double Stacked Terminals
All our boards are fitted with double-stacked terminals, allowing for easier access to the terminal bars during wiring. This design improves convenience and efficiency, making the installation process quicker and more organised.

3



Internal Earth Nut
Our boards are equipped with an internal earth nut located on the side, serving as the main earth connection. This feature ensures a secure and reliable grounding point, enhancing safety and compliance with electrical standards.

4



Space for Cables
Our boards are designed with ample space for wiring, providing easy access to devices and terminals, which simplifies the installation process and ensures a neat, organised setup.

5



Energy Monitor
The Energy Meter can be easily installed inside our distribution boards or even in an extension board, providing flexible options for energy monitoring within your system.

6



Additional Connection to Phases or Converting to Single Phase
The top terminals can be used to extend the board for additional ways, offering flexibility in system configuration. This extension is compatible with cables up to 25mm².

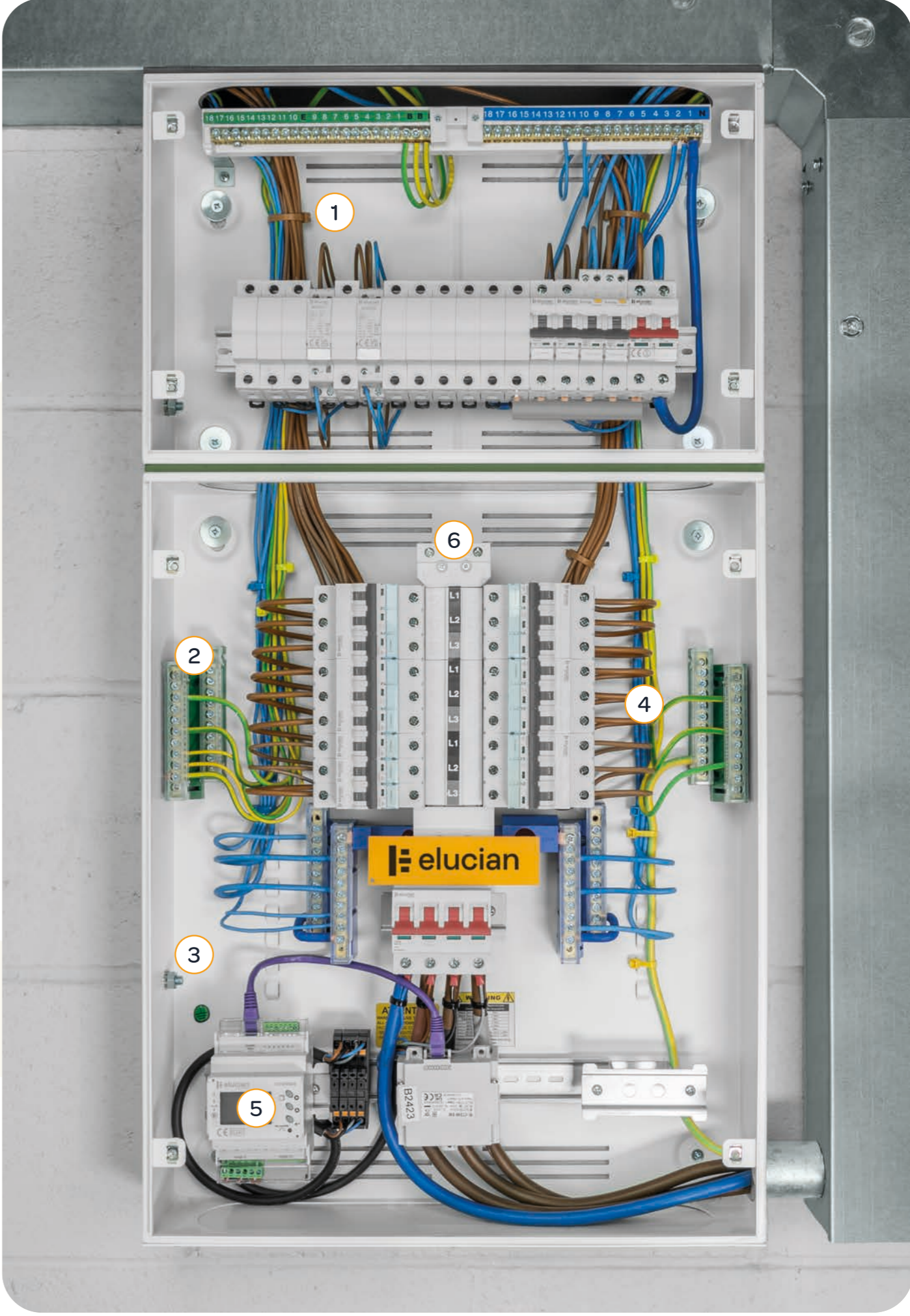

4 & 6 Way Three Phase Distribution Board.

*Gear Tray and Busbars pre-installed onto all 4 & 6 Way Distribution Boards.



*Example 6 Way Three Phase Distribution Board shown.

Technical Information

Mains Isolator Compatibility	125A Mains Incomer / RCCB
Colour	White finish (RAL 9003)
Mounting Type	Surface
Material of Base & Door	Steel
Material of Plastic Components	ABS/PC
IP Rating / IK Rating	IP3X / IK05
Busbar Current Rating	125A
Busbar Rating	25kA
Fire Resistance	650°C / 30s
Ambient Temperature	-5 to +40°C, max 95% humidity
Storage Temperature	-40 to +75°C
Warranty	10 years
Outgoing Protection	MCB, RCBO, AFDDs
Incoming Line Terminal	50mm ² or M8
Outgoing Earth Terminals	25mm ²
Earth Stud	M8 Stud
Incoming Neutral Terminals	50mm ² or M8
Outgoing Neutral Terminals	25mm ²
Gland Plate	Top and Bottom Removable
Locking	Key lock
Voltage Range	230/400V
Standards	BS EN 61439-3

Product SKU	No. of Three Phase Ways	No. of Single Phase Ways	Dimensions (W x H x D)	Fixing Centres (X)	Fixing Centres (Y)
TPEB4	4	12	450 x 500 x 140mm	380mm	437mm
TPEB6	6	18	450 x 560 x 140mm	380mm	492mm

Things to know...

Our 4 & 6 Way Distribution Board is designed specifically to only work with a 125A incomer, ensuring optimal performance and compatibility for safe and efficient power distribution.

Main Incomers on [Page 28](#)

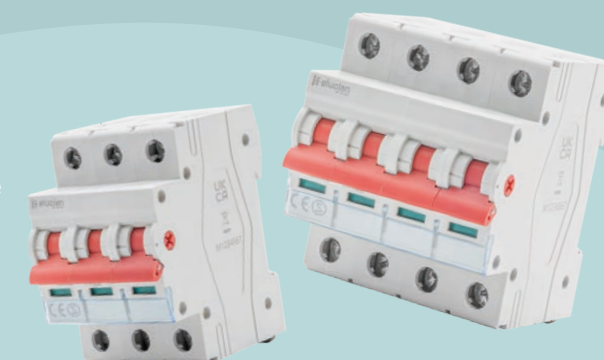

8, 12, 16, 20 & 24 Way Three Phase Distribution Board.



*Example 16 Way Three Phase Distribution Board shown.

Technical Information

Mains Switch Compatibility	125A Mains Incomer / 250A Mains Incomer / RCCB
Colour	White finish (RAL 9003)
Mounting Type	Surface
Material of Base & Door	Steel
Material of Plastic Components	ABS/PC
IP Rating / IK Rating	IP3X / IK05
Busbar Current Rating	250A
Busbar Rating	25kA
Fire Resistance	650°C / 30s
Ambient Temperature	-5 to +40°C, max 95% humidity
Storage Temperature	-40 to +75°C
Warranty	10 years
Outgoing Protection	MCB, RCBO, AFDDs
Incoming Line Terminal	50mm ² or M8
Outgoing Earth Terminals	25mm ²
Earth Stud	M8 Stud
Incoming Neutral Terminals	125A: 50mm ² or M8
Outgoing Neutral Terminals	25mm ²
Gland Plate	Top and Bottom Removable
Locking	Key lock
Voltage Range	230/400V
Standards	BS EN 61439-3

Product SKU	No. of Three Phase Ways	No. of Single Phase Ways	Dimensions (W x H x D)	Fixing Centres (X)	Fixing Centres (Y)
TPEB8	8	24	450 x 760 x 140mm	380mm	697mm
TPEB12	12	36	450 x 870 x 140mm	380mm	807mm
TPEB16	16	48	450 x 980 x 140mm	380mm	917mm
TPEB20	20	60	450 x 1100 x 140mm	380mm	1037mm
TPEB24	24	72	450 x 1230 x 140mm	380mm	1137mm

Things to know...

Our 8, 12, 16, 20, and 24-way boards allow you to choose between any of our RCCBs, 125A Isolator, or 250A Isolator to suit your installation needs.

Main Incomers on [Page 28](#)



Accessories for seamless Three Phase installations.

Enhance your Three Phase Distribution Board installations with our range of essential electrical accessories, carefully selected to support both functionality and efficiency. Designed for compatibility and reliability, these high-quality products simplify the installation process while ensuring a professional and compliant finish.

We've got you covered.

The Unicrimp® range includes cable ties, crimp terminals, PVC tape, copper tube terminals, cable clips, brass/nylon glands, tail glands and earth sleeving – providing everything required to harness cable between the consumer unit and the end accessory.

Compliance with Regulation 522.8.5



Lever Connectors & Connection Boxes

Focusing on strong, quick and reliable solutions, the new Q-Nect range offers great versatility for electrical connections. Each product is packed with features which makes your installations quicker and easier.



Fire Rated Accessories

Don't get caught out by the latest regs! Explore our range of fire rated products and prevent cables from premature collapse during a fire and keep emergency services and the public safe.



Q-CRIMP®

Narrow Palm Copper Lugs

Available from 35mm² to 150mm², our Narrow Palm Copper Lugs provide high-performance and secure connections. Supplied with an integrated stud, they're made from durable copper for reliable conductivity in industrial and commercial applications.



OBI

MULTI-SURFACE
CONSTRUCTION
SEALANT & ADHESIVE

No.1 Sealant & Adhesive

The No.1 hybrid sealant and adhesive. OBI bonds and seals a range of materials, works in damp conditions and even under water. User-friendly, hybrid polymer formulation for the ultimate in bonding and sealing.



Three Phase Circuit Protection Devices.

We offer a comprehensive range of Three Phase Circuit Protection Devices designed to ensure safety, reliability, and efficiency in commercial and industrial installations. Built to meet the highest standards, these devices are ideal for safeguarding complex electrical systems while ensuring seamless operation and compliance.

Main Incomers

Main Isolator Kits



Product Listing on [Page 28](#)



Main Incomers

Type A & B RCCBs



Product Listing on [Page 30](#)



Protective Devices

RCBOs



Product Listing on [Page 36](#)



Protective Devices

1 & 3 Pole MCBs



Product Listing on [Page 37](#)



Protective Devices

SPD & Cartridges



Product Listing on [Page 32](#)



Protective Devices

AFDDs



Product Listing on [Page 34](#)



Protective Devices

Energy Meter Kits



Product Listing on [Page 41](#)



Protective Devices

Blank Modules



Product Listing on [Page 42](#)



Explore all our Mains Isolator Kits.



Lock Off Capabilities.

Our Locking Kits are designed to attach to the moving part of the Main Isolator, usually a switch toggle (rocker switch) which moves from the on to off position. This ensures the switch cannot be switched back on while work is being carried out.

Lock Off Kit on [Page 44](#)



Incomer of your choice.

Our 8, 12, 16, 20, and 24-way boards offer versatile configurations, allowing you to choose between any of our RCCB's, 125A Isolator, or 250A Isolator to suit your installation needs.

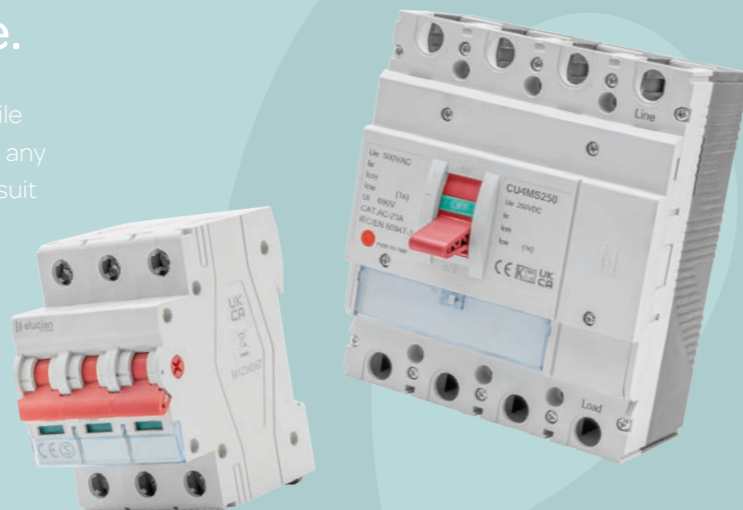

Distribution Boards on [Page 21](#)



125A Mains Isolator Kit

Product SKU	Poles	Current	Terminal Capacity
TPMS3125KS	3	125A	50mm ²
TPMS4125KS	4 (3+N)	125A	50mm ²

*For use on 4 & 6 Way Distribution Boards only.



125A Mains Isolator Kit

Product SKU	Poles	Current	Terminal Capacity
TPMS3125K	3	125A	50mm ²
TPMS4125K	4 (3+N)	125A	50mm ²



250A Mains Isolator Kit

Product SKU	Poles	Current	Terminal Capacity
TPMS3250K	3	250A	95mm ²
TPMS4250K	4 (3+N)	250A	95mm ²

*Accepts 120mm M8 Narrow Palm Lugs.

Type A & B RCCB devices. Reliable protection for every installation.

Type A RCCB

Type A RCCBs detect and disconnect both AC and pulsating DC, making it ideal for protecting devices like LED lighting, dimmers, and appliances with electronic components, ensuring enhanced safety in modern electrical installations.

Ensures tripping for:

- Residual AC Currents
- Pulsating DC Currents



Type B RCCB

Type B RCCBs are designed to detect and disconnect both AC, pulsating DC, and smooth DC. It provides advanced protection for installations with equipment that may produce continuous DC currents, such as solar inverters, electric vehicle charging stations, and other specialized electronic systems.

Ensures tripping for:

- Residual AC Currents
- Pulsating DC Currents
- Smooth DC Currents



Type A - RCCB

Product SKU	Poles	Type	Current	Milliamp
CU4RCD63A	4 (3+N)	A	63A	30mA
CU4RCD80A	4 (3+N)	A	80A	30mA
CU4RCD100A	4 (3+N)	A	100A	30mA
*CU4RCD1100A	4 (3+N)	A	100A	100mA
*CU4RCD3100A	4 (3+N)	A	100A	300mA
*CU4RCDTD100A (Time Delay RCD)	4 (3+N)	S	100A	100mA
*CU4RCDTD3100A (Time Delay RCD)	4 (3+N)	S	100A	300mA

Type B - RCCB

Product SKU	Poles	Type	Current	Milliamp
CU4RCD25B	4 (3+N)	B	25A	30mA
CU4RCD40B	4 (3+N)	B	40A	30mA
CU4RCD63B	4 (3+N)	B	63A	30mA



*To use these RCCBs as isolators, you will need to use the **TPRCDLINK**, which can be found on [page 44](#).

Ultimate Surge Protection. Explore our SPD range.

Type 1+2 SPD

A Type 1+2 SPD is a hard-wired, permanently connected device installed between the utility transformer and the main service equipment. It protects against external surges and direct lightning strokes.



Safeguard Your Installation



Type 2 SPD

A Type 2 SPD is installed on the load side of the main service equipment, typically at the service entrance or in distribution panels. It protects against internal surges and indirect lightning strokes, safeguarding equipment from damaging voltage spikes.



Overvoltage Protection



Surge Protective Devices

Product SKU	Poles	Type	Operating Voltage	Breaking Capacity
CU4SPD275	4 (3+N)	1+2	275Uc (V~)	40kA
CU4SPD275T2	4 (3+N)	2	275Uc (V~)	40kA

- Copper Earth Plate supplied
- 625mm, 6mm² Tails supplied
- Built-in overcurrent protection (Rated current: 300A)

SPD Cartridges

Product SKU	Poles	Type	Operating Voltage	Breaking Capacity
CU4SPDC275	1	1+2	275Uc (V~)	40kA
CU4SPDC275T2	1	2	275Uc (V~)	40kA

Advanced protection. Discover our AFDD solutions.



B & C Curve

Our AFDDs are available in B and C curves, with the following currents, 6A, 10A, 16A, 20A, 25A, 32A and 40A.



Self Test Function

AFDDs feature a self-test function that activates on first power-up and runs hourly to ensure full operation.



Neutral Out Tails

Our AFDDs provide a 1m Neutral Tail as standard. The AFDDs are also single width (18mm).



B Curve - AFDD + RCBO

Product SKU	Poles	Type	Current	Milliamp	Breaking Capacity
CU1AFDD6B10	1	A	6A	30mA	10kA
CU1AFDD10B10	1	A	10A	30mA	10kA
CU1AFDD16B10	1	A	16A	30mA	10kA
CU1AFDD20B10	1	A	20A	30mA	10kA
CU1AFDD25B10	1	A	25A	30mA	10kA
CU1AFDD32B10	1	A	32A	30mA	10kA
CU1AFDD40B10	1	A	40A	30mA	10kA

• 1m Length Fly-Lead Supplied



B Curve - AFDD + MCB

Product SKU	Poles	Current	Breaking Capacity
CU1AFMCB6B10	1	6A	10kA
CU1AFMCB10B10	1	10A	10kA
CU1AFMCB16B10	1	16A	10kA
CU1AFMCB20B10	1	20A	10kA
CU1AFMCB32B10	1	32A	10kA
CU1AFMCB40B10	1	40A	10kA

• 1m Length Fly-Lead Supplied



C Curve - AFDD + RCBO

Product SKU	Poles	Type	Current	Milliamp	Breaking Capacity
CU1AFDD6C10	1	A	6A	30mA	10kA
CU1AFDD10C10	1	A	10A	30mA	10kA
CU1AFDD16C10	1	A	16A	30mA	10kA
CU1AFDD20C10	1	A	20A	30mA	10kA
CU1AFDD25C10	1	A	25A	30mA	10kA
CU1AFDD32C10	1	A	32A	30mA	10kA
CU1AFDD40C10	1	A	40A	30mA	10kA

• 1m Length Fly-Lead Supplied

Explore our full range of RCBOs.

What is an RCBO?

These devices combine the functionality of an MCB and RCD into one single device/module.

Available as a Unswitched Neutral, Type A RCD with different inrush curve types B or C, these protective devices have been miniaturised to maximise the available space above for termination or final circuits.

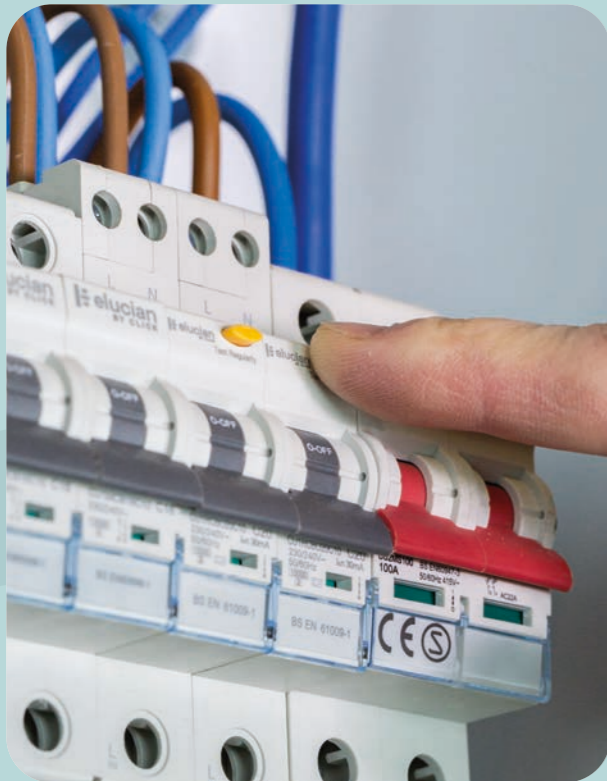

RCBO - Residual Current Operated Circuit Breaker, with integrated over-current protection.

1m Fly-Lead

The Neutral fly lead has been made long enough to ensure safe connection to the dedicated Neutral bars in the distribution boards.

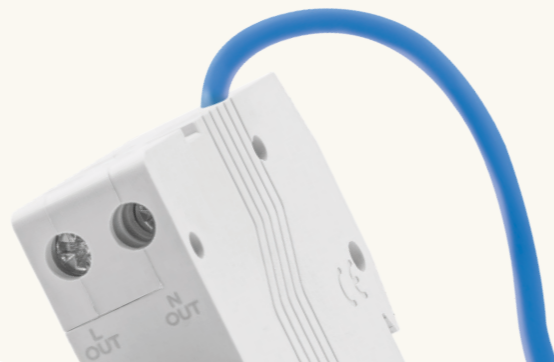

10kA Breaking Capacity

A 10kA rating for an RCBO means it can safely handle and interrupt fault currents up to 10,000 amps. This high rating ensures the device is capable of protecting circuits in environments with large fault currents, offering greater safety and reliability.



B Curve - RCBO

Product SKU	Poles	Type	Current	Milliamp	Breaking Capacity
CU1RCBO6B10	1	A	6A	30mA	10kA
CU1RCBO10B10	1	A	10A	30mA	10kA
CU1RCBO16B10	1	A	16A	30mA	10kA
CU1RCBO20B10	1	A	20A	30mA	10kA
CU1RCBO25B10	1	A	25A	30mA	10kA
CU1RCBO32B10	1	A	32A	30mA	10kA
CU1RCBO40B10	1	A	40A	30mA	10kA

• 1m Length Fly-Lead Supplied

C Curve - RCBO

Product SKU	Poles	Type	Current	Milliamp	Breaking Capacity
CU1RCBO6C10	1	A	6A	30mA	10kA
CU1RCBO10C10	1	A	10A	30mA	10kA
CU1RCBO16C10	1	A	16A	30mA	10kA
CU1RCBO20C10	1	A	20A	30mA	10kA
CU1RCBO25C10	1	A	25A	30mA	10kA
CU1RCBO32C10	1	A	32A	30mA	10kA
CU1RCBO40C10	1	A	40A	30mA	10kA

• 1m Length Fly-Lead Supplied

Explore all our 1 & 3 Pole MCBs.



B Curve - MCB

Product SKU	Poles	Current	Breaking Capacity
CU1MCB6B10	1	6A	10kA
CU1MCB10B10	1	10A	10kA
CU1MCB16B10	1	16A	10kA
CU1MCB20B10	1	20A	10kA
CU1MCB25B10	1	25A	10kA
CU1MCB32B10	1	32A	10kA
CU1MCB40B10	1	40A	10kA
CU1MCB50B10	1	50A	10kA
CU1MCB63B10	1	63A	10kA



C Curve - MCB

Product SKU	Poles	Current	Breaking Capacity
CU1MCB6C10	1	6A	10kA
CU1MCB10C10	1	10A	10kA
CU1MCB16C10	1	16A	10kA
CU1MCB20C10	1	20A	10kA
CU1MCB25C10	1	25A	10kA
CU1MCB32C10	1	32A	10kA
CU1MCB40C10	1	40A	10kA
CU1MCB50C10	1	50A	10kA
CU1MCB63C10	1	63A	10kA



D Curve - MCB

Product SKU	Poles	Current	Breaking Capacity
CU1MCB6D10	1	6A	10kA
CU1MCB10D10	1	10A	10kA
CU1MCB16D10	1	16A	10kA
CU1MCB20D10	1	20A	10kA
CU1MCB25D10	1	25A	10kA
CU1MCB32D10	1	32A	10kA
CU1MCB40D10	1	40A	10kA
CU1MCB50D10	1	50A	10kA
CU1MCB63D10	1	63A	10kA



B Curve - MCB

Product SKU	Poles	Current	Breaking Capacity
CU3MCB6B10	3	6A	10kA
CU3MCB10B10	3	10A	10kA
CU3MCB16B10	3	16A	10kA
CU3MCB20B10	3	20A	10kA
CU3MCB25B10	3	25A	10kA
CU3MCB32B10	3	32A	10kA
CU3MCB40B10	3	40A	10kA
CU3MCB50B10	3	50A	10kA
CU3MCB63B10	3	63A	10kA



C Curve - MCB

Product SKU	Poles	Current	Breaking Capacity
CU3MCB6C10	3	6A	10kA
CU3MCB10C10	3	10A	10kA
CU3MCB16C10	3	16A	10kA
CU3MCB20C10	3	20A	10kA
CU3MCB25C10	3	25A	10kA
CU3MCB32C10	3	32A	10kA
CU3MCB40C10	3	40A	10kA
CU3MCB50C10	3	50A	10kA
CU3MCB63C10	3	63A	10kA



D Curve - MCB

Product SKU	Poles	Current	Breaking Capacity
CU3MCB6D10	3	6A	10kA
CU3MCB10D10	3	10A	10kA
CU3MCB16D10	3	16A	10kA
CU3MCB20D10	3	20A	10kA
CU3MCB25D10	3	25A	10kA
CU3MCB32D10	3	32A	10kA
CU3MCB40D10	3	40A	10kA
CU3MCB50D10	3	50A	10kA
CU3MCB63D10	3	63A	10kA



2 Pole - 20A Contactors (1 Module)

Product SKU	Description
MC20211	2 Pole 1 Module 20A Contactor, 1 x Normally Open, 1 x Normally Closed Contacts
MC20220	2 Pole 1 Module 20A Contactor, 2 x Normally Open Contacts
MC20202	2 Pole 1 Module 20A Contactor, 2 x Normally Closed Contacts



4 Pole - 40A Contactors (3 Module)

Product SKU	Description
MC40422	4 Pole 3 Module 40A Contactor, 2 x Normally Open, 2 x Normally Closed Contacts
MC40431	4 Pole 3 Module 40A Contactor, 3 x Normally Open, 1 x Normally Closed Contacts
MC40440	4 Pole 3 Module 40A Contactor, 4 x Normally Open Contacts
MC40404	4 Pole 3 Module 40A Contactor, 4 x Normally Closed Contacts



4 Pole - 25A Contactors (2 Module)

Product SKU	Description
MC25422	4 Pole 2 Module 25A Contactor, 2 x Normally Open, 2 x Normally Closed Contacts
MC25431	4 Pole 2 Module 25A Contactor, 3 x Normally Open, 1 x Normally Closed Contacts
MC25404	4 Pole 2 Module 25A Contactor, 4 x Normally Closed Contacts
MC25440	4 Pole 2 Module 25A Contactor, 4 x Normally Open Contacts



4 Pole - 63A Contactors (3 Module)

Product SKU	Description
MC63422	4 Pole 3 Module 63A Contactor, 2 x Normally Open, 2 x Normally Closed Contacts
MC63431	4 Pole 3 Module 63A Contactor, 3 x Normally Open, 1 x Normally Closed Contacts
MC63404	4 Pole 3 Module 63A Contactor, 4 x Normally Closed Contacts
MC63440	4 Pole 3 Module 63A Contactor, 4 x Normally Open Contacts

Energy Meters for smarter installations.



Energy Meter Kits

Product SKU	Description
CU4EM125K	125A Three Phase Energy Meter Kit
<ul style="list-style-type: none"> • Three Phase Energy Meter • 125A Energy Meter CT 	<ul style="list-style-type: none"> • 30cm Length RJ45 Cable • 1m Power Supply Cable
CU4EM250K	250A Three Phase Energy Meter Kit
<ul style="list-style-type: none"> • Three Phase Energy Meter • 250A Energy Meter CT 	<ul style="list-style-type: none"> • 30cm Length RJ45 Cable • 1m Power Supply Cable
RJ45150	RJ45 Cable - 1500mm

Internal Installation.

Our Three Phase Multi-Function Energy Meter Kit is designed for seamless integration into all of our distribution boards. Supplied as a complete kit, including an Energy Meter CT, it simplifies installation with fewer cables required, providing everything you need for quick and efficient setup.

- Directly installed into our boards
- Energy Meter CT provided in both kits
- Fewer cables required



Example installation on [Page 17](#)



Blank Modules for every installation.

Protective Devices



Blank Modules

Product SKU	Description
CU31BLANK	Single Way Din Rail Blank Module with 125A & 250A Adaptors
CU33BLANK	Triple Way Din Rail Blank Module with 125A & 250A Adaptors
CUBLANKP12	12 Way Plastic Blank Plate (2 x 6 Way)

Extension Boards and Enclosures.

Extension Boards



Product SKU	Description	Dimensions (W x H x D)
TPXB	Extension Board without Pan Assembly	450 x 280 x 140mm
TPXB18S	18 Way Single Phase Extension Board	450 x 280 x 140mm
XBP18S	18 Way Single Extension Board Pan Assembly	

Spares & accessories, everything you need.



Product SKU	Description
TP2SP	Three Phase to Single Phase converter



Product SKU	Description
TP125CAP	125A busbar caps (10)
TP250CAP	250A busbar caps (10)



Product SKU	Description
TPLOCK	Three Phase Isolator Locking kit

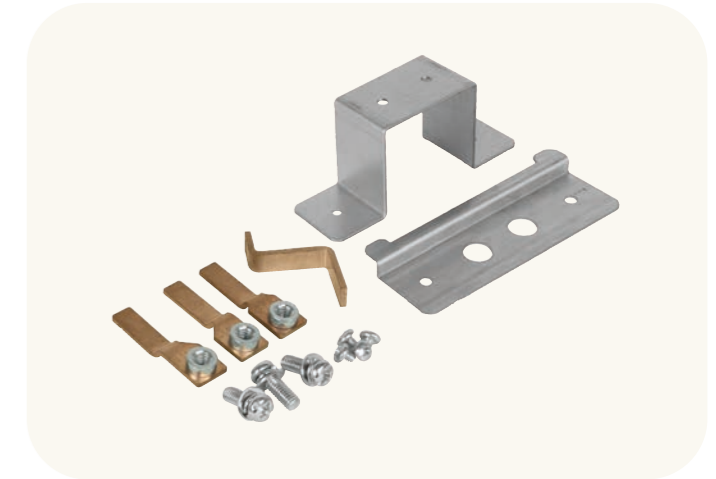

Product SKU	Description
TPRCDLINK	Three phase RCCB Link Kit



Product SKU	Description
TPPLATE	Three Phase Gland plate

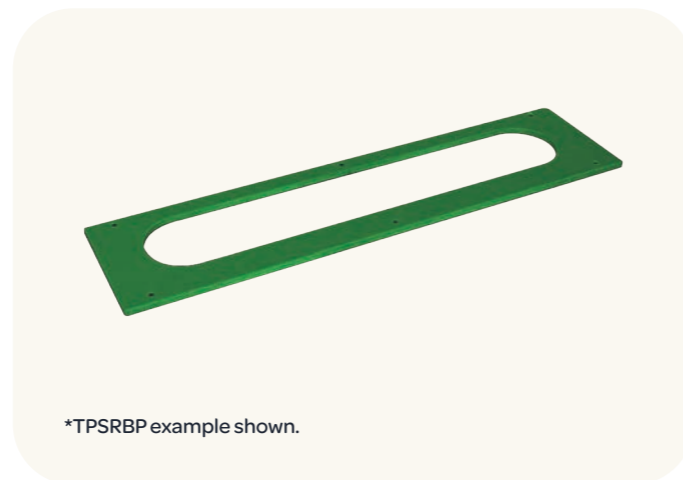

Product SKU	Description
TPSRBP	Synthetic Bonded Resin Paper with Slot



Product SKU	Description
TPLABELK	Three Phase Label pack



Product SKU	Description
TP250BS3	3 Pole Three Phase bottom shroud for 250A Main switch
TP250BS4	4 Pole Three Phase bottom shroud for 250A Main switch

Time Switches. Complete your install.

NFC DIN Rail Time Switches

NFC (Near Field Communication) is a wireless communication protocol that allows you to program the switch using the free Sangamo Connect app on an Android NFC Smart phone.

This works the same way as contactless bank cards, oyster travel cards and mobile payment systems. You set the program up on the app and hold the phone next to the switch to read, write or transfer programming times.

Bluetooth DIN Rail Time Switches

Bluetooth is a wireless communication protocol that allows programming of the switch using the free APP available on Android and IOS smart phones and tablets. This works the same way as bluetooth headphones and speakers. The program is setup on the APP and transfers to the switch when the smart device is held in close proximity.



DIN Rail Time Switches

All Sangamo's DIN Rail mountable time switches are designed for 35mm "Top Hat" rail. Switches come in 1, 2 or 4 modules, each module is 17.5mm wide, which fits the required width in the DIN enclosure.

Using the 25195 USB Hub and Easy Vue software or 25196 USB Hub with bluetooth and connect app programs can be transferred to a 25193 data key and then to one or multiple switches. 1 module switches do not require a Data Key as the fascia can be removed and slotted into the Hub directly.



NFC DIN Rail Time Switches



72113NFC

Standard NFC 2 Module 1 Channel, 7 Day, 56 Operations

72102NFC

Astro NFC Module 1 Channel, 24HR Timer, 4 Operations

72103NFC

Astro NFC 2 Module 1 Channel, 7 Day, 56 Operations

Bluetooth DIN Rail Time Switches



SC2811PRO4

Standard Bluetooth 2 Module 1 Channel, 7 Day, 100 Operations

SC2813PRO4

Astro Bluetooth 2 Module 1 Channel, 7 Day, 100 Operations

SC2823PRO4

Astro Bluetooth 2 Module 2 Channel, 7 Day, 100 Operations

DIN Rail Time Switches



71111

Standard 1 Module 1 Channel, 7 Day, 46 Operations

72112

Standard 2 Module 1 Channel, 7 Day, 46 Operations

25162

Standard 2 Module 1 Channel, Yearly, 300 Operations

26404

Standard 4 Module 4 Channel, 7 Day, 300 Operations

11002

Standard 1 Module 24HR Timer

71101

Astro 1 Module 1 Channel, 7 Day, 60 Operations

72101

Astro 2 Module 1 Channel, 7 Day, 60 Operations

72201

Astro 2 Module 2 Channel, 7 Day, 60 Operations

Single Phase Consumer Units and Circuit Protection Devices.

Single Phase Brochure

Check out our Single Phase Distribution brochure and explore our huge range of Metal Consumer Units, Circuit Protection Devices and accessories.



*Scan the QR code to view our Single Phase brochure.



Metal Consumer Units.

Elucian® offers a versatile range of Single Phase Metal Consumer Units designed for safety, reliability, and ease of installation, suitable for various domestic and commercial applications.

- Split Load Units
- Split Load Units (Surge Protection)
- Combination Units
- Combination Units (Surge Protection)
- Switch Disconnector Units
- Switch Disconnector Units (Surge Protection)
- Dual Row Switch Disconnector Units (Surge Protection)
- Mini Units (Garage)

elucianuk.com



Circuit Protection Devices.

Our Elucian® range of Protective Devices are easy to install, suitable for residential and light commercial environments, they provide protection against earth faults to ensure people's safety against electrocution and fires.

Main Incomers

- Mains Isolator Switch
- RCCB (Type A & B)

Protective Devices

- RCBO (B & C Curve)
- AFDD (B & C Curve)
- MCB (B, C & D Curves)
- Contactors
- SPD
- Energy Meters
- Blank Modules

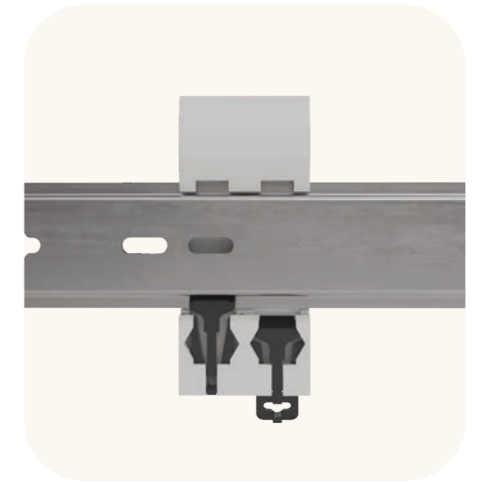
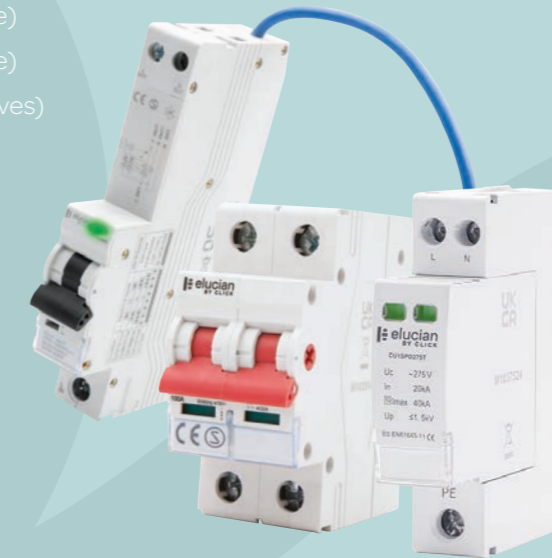

Spares & Accessories.

The Elucian® range offers a wide variety of compatible accessories, including cable entry plates and pattress mounts, to make any installation easier and faster.

- Terminal Bars
- Busbar & Cover Sets
- DIN Rails
- SPD Cartridge
- Grommet Strips
- Retro Fit Locking Devices
- Mains Clamp Components
- Adhesive Labels
- Pattress Mounts
- Flush Consumer Unit Lids
- Cable Entry Plates
- Recess Frames



More from the Scolmore® Group.

Wiring Accessories.

Click® is one of the UK's leading manufacturers of electrical accessories. The company is proud to be a British-based, family-run business with an international reputation for quality, innovation and exemplary customer service.



Lighting Solutions.

The comprehensive collection of lighting products from Ovia® will provide solutions for a whole spectrum of projects in a broad variety of sectors, including domestic, commercial, industrial, utility, amenity, emergency lighting and floodlighting.



Cable & Wiring Accessories.

Unicrimp® offers a comprehensive range of cable accessories under the Q-crimp, Q-Fire, and Q-Nect brands, exclusively for the electrical trade. All products meet strict quality standards and comply with the latest regulations.



- Cable Ties
- Crimp Terminals
- PVC Tape
- Copper Tube Terminals
- Cable Clips
- Brass & Nylon Glands
- Tail Glands
- Earth Sleeving

Helps to provide compliance with Regulation 522.8.5.



Fire & Security Products.

ESP® is a leading supplier of electronic security and fire protection products, including Smart Security, CCTV, Access Control, EVAC, Home Safety Solutions, Fire Protection, Emergency Lighting, and Sangamo Time Switches and Heating Controls.



No.1 Sealant and Adhesives.

The No.1 hybrid sealant and adhesive. OB1 bonds and seals a range of materials, works in damp conditions and even under water. User-friendly, hybrid polymer formulation for the ultimate in bonding and sealing.



United Kingdom



Scolmore House, Mariner,
Lichfield Road Industrial Estate,
Tamworth, Staffordshire, B79 7UL

+44 (0) 1827 63454
sales@scolmore.com
www.scolmore.com



Southern Ireland



18 Corrig Road,
Sandyford Industrial Estate,
Dublin, D18 WV79, Ireland

+353 (1) 2811 122
sales@clicklitehouse.ie
www.clicklitehouse.ie



Scolmore® Middle East



Lake Central Tower,
Office 1803, Business Bay,
Dubai, UAE

+971 4589 6552
sales@scolmoreme.com
www.scolmoreme.com



**CARBON
BALANCED
PRINT**

www.carbonbalancedprint.com
CBP2262